

---

# Variable Air Volume Systems

Course No: M06-007

Credit: 6 PDH

---

A. Bhatia

---

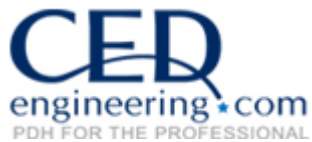

Continuing Education and Development, Inc.  
9 Greyridge Farm Court  
Stony Point, NY 10980

P: (877) 322-5800

F: (877) 322-4774

[info@cedengineering.com](mailto:info@cedengineering.com)

---

# Contents

1	Introduction	A-5
	Background	A-5
	Summary	A-6
	Controllability Classifications for VAV Systems	A-7
	Pressure Dependent	A-8
	Volume (cfm) Limiting	A-8
	Pressure Independent	A-9
	Application of Controllability Classifications	A-10
	Control Considerations	A-11
	Example of a VAV System Control	A-12
2	Air Handling Units	A-18
	Basic Fan Types	A-18
	Centrifugal Fans	A-18
	Axial Fans	A-20
	Other Fan Types	A-21
	Fan Classes	A-22
	Fan Laws and Sizing	A-23
	Fan Curves vs. System Curves	A-30
	Fan Discharge Control	A-31
	Discharge Air Dampers	A-32
	Variable Inlet Vanes	A-32
	Variable Pitch Blades	A-33
	Variable Speed Drives	A-33
	Heating and Cooling Coils	A-34
	Direct Expansion Coil Circuiting for Variable Air Volume Systems (DX/VAV)	A-36
	Horizontal split/face split coils	A-38
	Vertical/row split coils	A-39
	Intertwined coil circuiting	A-39
	Filters	A-40
	Mixing Box	A-42
	Humidification	A-43
3	Duct Design and Construction	A-45
	Duct Pressure Classification	A-46
	General Approach to Duct Design	A-48

Locating and Selecting Outlets	A-49
Locating and Selecting Returns and Exhaust Devices	A-50
Zoning	A-53
Preliminary Duct Layout	A-53
Duct Sizing	A-54
Duct Design Methods	A-55
Equal Friction Method	A-55
Static Regain Method	A-55
T-Method	A-56
Extended or Semi-extended Plenums	A-57
Velocity Reduction	A-57
Total Pressure	A-58
Constant Velocity	A-58
Duct Fabrication and Construction	A-59
Fibrous Glass Ductwork	A-60
Sealing Ducts	A-61
Provisions During Design for Testing, Adjusting, and Balancing	A-61
4 VAV Boxes, Diffusers, and Dampers	A-64
VAV Boxes	A-64
Fan Powered VAV Box	A-64
Single Duct VAV Terminal	A-64
Single Duct VAV Box with Reheat	A-64
Dual Duct VAV Terminal	A-64
Bypass VAV Terminal	A-65
Retrofit Terminals	A-65
Diffusers	A-66
Dampers	A-70
5 VAV Controls	A-72
Thermostats	A-74
Explanation of Thermostat Operation	A-74
Applications	A-76
VAV System Control	A-78
Direct Digital Control (DDC)	A-81
6 Acoustical Considerations	A-85
7 Acceptance Testing	A-89
Air Measuring Instruments	A-90

---

Manometers	A-90
Electronic Meters	A-91
Dry-Type Pressure Gauges (Magnehelic)	A-91
Pitot Tube	A-91
Rotating Vane Anemometer	A-95
Hot-Wire Anemometer	A-95
Flow Measuring Hood	A-95
Testing, Adjusting, and Balancing	A-96
Preliminary Steps	A-96
Final Testing, Adjusting, and Balancing Procedures	A-97
Acceptance Testing for Performance Verification	A-99
Appendix A Annex: Humidification	A-103
The Need to Humidify	A-103
Psychrometrics	A-104
Absorption	A-105
Fog Control	A-106
Humidifier Types	A-107
Area Type Humidifiers (for wide open spaces)	A-107
Duct Type Steam Humidifiers	A-108
Single Dispersion Tube Humidifiers	A-109
Multiple Dispersion Tube Humidifiers	A-111
Trouble Shooting	A-111
Too Much Humidity	A-111
Too Little Humidity	A-111
Humidifier Discharges Water	A-111
Humidity Swings Above and Below Control Point	A-112
Glossary	A-113
Abbreviations	A-119
Bibliography	A-120

# 1 Introduction

## Background

A variable air volume (VAV) system basically supplies air at a constant temperature and varies the air quantity delivered to each zone to match the change in room load. In a VAV system, an air handling unit (AHU) cools or heats air to accommodate the zone with the most extreme requirements, supplying the air through ducts to various zones. At the individual zone or space, the amount of air to be provided is regulated by dampers within a VAV box or terminal.

Use of VAV systems have been a popular energy conservation choice since the 1970s. After much experience and many customer complaints, it was learned that VAV systems needed to be continually controlled. This is in contrast to constant volume systems that are manually balanced and then left alone. Thermostatically controlled volume dampers (air valves) were used for many years, particularly in low static pressure air distribution systems. In most cases, performance was less than satisfactory. They were often a compromise to achieve lower cost than using proportioning water valves, face and bypass dampers, or other control means. However, the development of higher velocity and higher pressure systems, and nondumping diffusers and grills, combined with larger zones, higher internal heating loads, and the rising cost of energy, have made VAV systems the most popular air distribution systems specified today.

Many VAV systems cause the flow of air, and therefore, the static pressure in both the supply and return duct systems to vary as the space load changes. At any given air valve position, as the static pressure changes, airflow changes. As airflow changes, the space temperature is also changed. If the load throughout the building changed gradually and at the same time, changes in static pressure would be approximately the same at each air terminal. This seldom happens. Due to building diversity, changing solar loads, fluctuating internal loads (from people, lighting, equipment, etc.) and static pressure, airflow fluctuates in trunk ducts and duct runouts as air valve positions change. When an air terminal valve closes, the static pressure in the adjacent runout and trunk duct will increase, resulting in increased airflow through the adjacent ductwork. This

change in airflow will affect the space temperature in the new area supplied by that ductwork because a higher volume of air (usually cooled) is now flowing into the area. The space thermostat in this area will eventually sense this change in temperature, and reposition its air valve for reduced flow. This reduced flow will cause a further increase in static pressure in adjacent ductwork and increase flow even further to other air terminals. If at this time another space has an increasing load, the terminal supplying that space would open, which would reduce static pressure in adjacent ductwork, and reduce airflow to the terminals that were previously throttled back. It is apparent that space thermostats alone can never stabilize a space temperature, since almost constant temperature swings will be the result.

On many systems, airflow is proportioned by "riding the fan curve." Duct static pressure can become quite high, causing increasing airflow and compounding control problems. Therefore, a means to control and at least limit static pressure is used on many systems. Control of static pressure and airflow by using inlet or outlet dampers on fans, or variable speed drives is intended to: (1) maintain a positive pressure to prevent infiltration, (2) assure that a minimum amount of outside air is supplied, and (3) keep duct pressure within the correct operating range of the air terminals. Controlling the central fan system will not completely eliminate fluctuation of duct static pressure in adjacent runouts, but this fluctuation should now be within the "correct operating range" of the air terminals. The next section describes the three primary classes of VAV terminals.

### **Summary**

Advantages of VAV systems:

- Low initial cost for large systems (compared to obtaining the same conditions for conventional systems) due to reduced fan sizes, ductwork, filters, and casings since the capacity is based on the peak instantaneous demand of all the spaces, instead of the sum of all the space peak demands.
- Lower operating costs due to reduced fan horsepower.
- Lower energy consumption since cooling and heating is provided only to the extent that it is required.
- Savings in mechanical space requirements due to smaller fans and ductwork.
- System is virtually self-balancing since boxes are set for maximum and minimum cfm.
- Excellent space condition controls.

Practical problems that may be encountered:

- Acoustical problems—noise generated by a terminal device varies with the static pressure across the device.
- Stratification and drafts—the air distribution patterns of conventional diffusers depend on the outlet air velocity. When airflow is reduced, the distribution pattern is changed and can cause stratification or drafts to occur.
- Unstable operation—variations in airflow cause variations in duct static pressure. As volume is reduced, duct system pressure drop is reduced and fan pressure increases. The combined effect of these two factors is higher static pressure at the terminal device as airflow is reduced. This is only a problem in pressure dependent and volume limiting systems.
- Control problems—(1) How to sense small changes in static pressure, (2) How to balance return air systems with variations in supply air, and (3) How to maintain a constant flow of outside air with variations in supply and return airflows.
- Not acceptable for some specific areas in hospitals because, at low load conditions, less air is discharged from supply outlets. This may not meet strict ventilation or humidity control requirements.
- Not especially adaptable to small volume system unless it is a low pressure system.

General applications:

- Ideal for buildings with internal spaces that have large internal heat gain.
- Most common for new institutional and office buildings where precise humidity control is not critical.
- VAV independent systems are satisfactory in schools when controls are applicable for varying loads.
- Ideal application for pressure dependent controllability is for low pressure systems with minimum load fluctuations.

## **Controllability Classifications for VAV Systems**

Understanding the static and flow variations of VAV terminals is important to understanding how they operate. From a controllability standpoint, all VAV terminals fall into one of three classifications: (1) Pressure Dependent, (2) Volume (CFM) Limiting, and (3) Pressure Independent.

### ***Pressure Dependent***

Pressure dependent terminals do not have controls that compensate for changes in duct static pressure. Therefore, the air volume delivered depends on upstream static pressure changes. These terminals are composed of air valves or dampers in an enclosure. A change in the thermostat signal will reposition the air valve.

Because they are subject to changes in airflow, these types of terminals seldom deliver the air quantity needed to satisfy space load. They depend on the thermostat sensing the change in room temperature. The room temperature variation is brought on by airflow fluctuations. Required airflow is achieved by the repositioning of the dampers. As airflow fluctuates, the inlet static pressure also changes. These changes in static pressure cause a repositioning of the damper. If the changes in load and static pressure are great, these devices will continually oversupply or undersupply air, causing temperature fluctuations in the space as well as changes in sound levels as they "overshoot" and "undershoot."

### ***Volume (cfm) Limiting***

These terminals will compensate for change in inlet static pressure (and provide controlled airflow) only when the cfm is at a maximum. They act as a high limit to prevent the airflow from exceeding the setting of the controller. Maximum load conditions, however, exist only a few hours of the year. As a result, the terminals exhibit the same "overshooting" and "undershooting" of supply air as do pressure dependent devices, except at the maximum setpoint.

There are two types of cfm-limiting air terminal controls: (1) those using mechanical volume regulators (MVR) and (2) those using pneumatic differential pressure controllers in conjunction with either an orifice or velocity sensing probe. The MVR is a spring loaded device. It repositions to reduce airflow when static pressure exceeds the setting. The MVR is used in conjunction with an air valve upstream that is operated by a motor and thermostat.

This provides poor control. As the thermostat attempts to reduce the volume by closing the air valve, the fixed setpoint MVR will attempt to correct for the loss and maintain full volume. Only when the air valve is almost closed and has "starved" the regulator will volume begin to be reduced.



The pneumatic differential pressure controller system replaces the MVR to provide high limit control.

Below the controller's setpoint (maximum design cfm), the thermostat controls the air valve actuator. Changes in static pressure can cause the air volume to vary. The terminal is pressure dependent. If the static pressure increases to a point where it exceeds the setpoint on the controller, the controller will take control of the air valve actuator and limit the volume. In this mode, it is compensating for inlet static changes. The pneumatic pressure controllers require main control air lines to the air terminal in addition to the thermostat connection. They also consume control air at a steady rate, increasing air compressor size and operating horsepower. Cfm limiting is not often specified today.

### ***Pressure Independent***

Air terminals of this type will deliver the required amount of air to satisfy the space load regardless of changes in system static pressure. Airflow is independent of upstream static pressure changes. Overshooting and undershooting of supply air is eliminated and system stability is enhanced. Typically, this type of control will incorporate a maximum flow setting, and often a minimum flow setting, which can be factory set. The maximum flow setting is most typically used when terminal reheat is incorporated. This capability, as well as being pressure compensated, greatly reduces the amount of time and expense associated with field air balancing or the need to rebalance after building tenant changes. The mechanics of maximum and minimum settings are explained in the following paragraphs.

Space demand changes are sensed by the room thermostat whose signal resets the volume control. Therefore, these systems are frequently called Variable Constant Volume Control (VCV) or more accurately Thermostatically Resettable Constant Volume Control.

Pressure compensated air terminals are of two types: (1) those using a mechanical volume regulator and (2) those using pneumatic controllers. Air terminals using mechanical volume regulators are basically the MVR described earlier with the setpoint adjusted or reset by thermostat demand. Some have spring loaded vanes, blade dampers, or shutters in the airstream that change the effective area of the terminal as inlet static changes to maintain volume.

Several types of available pneumatic reset controls, when applied to an air terminal air valve, will provide thermostatically resettable pressure compensation. Two types are discussed here. One type uses the diaphragm principle of the differential pressure controller. Pitot tube type sensors measuring total pressure and static pressure are used to determine actual velocity pressure. Some pitot tube sensors magnify the velocity pressure 1-1/2 to 2 times. This magnification is necessary because the differential pressure controllers must have an adequate signal to operate the diaphragm assembly properly. If the air valve throttles too low, the velocity pressure signal becomes too small to be useful. Magnification of the velocity pressure signal at the sensor extends the accuracy of the differential pressure controller. Magnification of the signal is accomplished by using a venturi type sensor and the principle of "static regain."

The second type of pneumatic thermostatically reset volume control senses velocity directly using a compressed air jet principle. It does not depend on measured air velocity pressures for operation. The pneumatic output signal is linear with air velocity and is insensitive to static pressure variations. The system can accurately control at velocities lower than differential pressure controllers.

The differential pressure type controller is easier to apply, and its accuracy is usually adequate for most comfort air conditioning applications. Although both types of controllers operate at lower velocities and static pressures than resettable MVRs, they require main control air lines to the air terminal in addition to the thermostat connection. They consume control air at a steady rate; again, this increases air compressor size and operating horsepower.

### ***Application of Controllability Classifications***

Because pressure dependent terminals (PDT) are subject to change in airflow, these types of terminals seldom deliver the air quantity needed to satisfy space load. They depend on the thermostat sensing the change in room temperature due to airflow fluctuations caused by changes in inlet static to reposition the damper to provide the required airflow. If the changes in load and static pressure are great, these devices will continually oversupply or undersupply air, causing temperature fluctuations in the space. PDTs are good in some applications, but in many VAV applications, they need some compensation for change in inlet static pressure to prevent the over- and undersupply of air.

Volume limiting (VL) controls provide this compensation, but only at a maximum cfm. They act as a high setting to prevent the airflow from exceeding the

setting of the controller. A VAV system under normal conditions will only reach maximum loads a few hours out of the year. During the remainder of the year, it has the same problems as the PDT. VL is not often specified today because they require consumption of control air at a steady rate, increasing air compressor size and operating horsepower. In general, the pressure dependent system with or without VL controls is best applied where load sizes and fluctuation of load is minimal. An example would be its use in the core of an office type building that is protected from extreme solar heat transfer loads or large wind loads that can cause infiltration.

Although VL control has its advantages, it does compare with pressure independent terminals (PIT). The PIT uses a high set point and a low set point. Because of its independence from static pressure control, the PIT will deliver the required amount of air to satisfy the space load regardless of changes in system static pressure. Therefore, the problems of the PDT are eliminated. An example application would be an auditorium space in an institutional building. The space can be filled to capacity for a few hours during the day and be empty the remaining time. Note that the load fluctuations that can occur when the space goes from completely empty to completely full would be too much for a pressure dependent system to control.

Pressure compensated terminals use mechanical volume regulators (MVR) or pneumatic controllers. Resettable MVR units have a slight static pressure disadvantage due to mechanical sensing of airflow. They also will not control at as low a velocity pressure as the reset units. As mentioned earlier, many types of pneumatic controllers are available. They provide high levels of accuracy sensing pressure differentials, and are excellent for both low and high pressure systems irrespective of the size of the load fluctuations.

### ***Control Considerations***

As described earlier, VAV systems need to be continually controlled in order to meet the demands of the space. Automatic controls for VAV systems must:

- Maintain temperature differences between heating and cooling mediums at maximum economical levels.
- Conserve fan horsepower. The supply and return fans must be throttled as the system load is reduced.

- Maintain supply duct static pressure at a constant minimum level. This reduces the possibility of high pressure drops within the system, which could cause objectionable noise.\*
- Maintain the volume differential between the supply and return fans and ensure that it is equal to the volume of the exhausts from the space. This is done to prevent the HVAC system from causing building pressurization problems.
- Produce system stability.

A fan is designed to discharge a given capacity of air at a given horsepower. In a VAV system, the amount of air needed depends on the needs of the space being served. Without continuous feedback control, the fan will always deliver full capacity at full horsepower and produce larger than necessary static pressures at the terminal units. Horsepower is wasted and operational savings are not realized with improper control schemes. When a control system is used to reset the fan capacity in accordance with the demands of the space, excess static pressure at the terminal units is eliminated, and the fan system horsepower adjusts to provide operational savings.

### ***Example of a VAV System Control***

Figure A-1 shows an example of a VAV system, the Modulating Zone Control System (MZCS).<sup>\*</sup> This system is exemplary of a VAV system because it is designed to introduce or convert air conditioning systems to complete VAV systems using:

- Modulating damper with room thermostat that matches available airflow to zone need.
- Bypass damper that diverts and returns unneeded air.
- Leaving air temperature sensor that provides heating and cooling capacity control.
- Discriminator that can sense temperatures in up to ten locations.

---

\* It must be remembered that noise is a result of pressure drops across terminal unit dampers or across diffusers. No amount of linearity of terminal unit control can reduce these effects. The room thermostat will be calling for air volumes required to meet the demand of the space, no more and no less.

\* OMNIZONE, "Modulating Zone Control Systems for VAV Applications of Air Conditioning Units," Huntington Beach, CA.

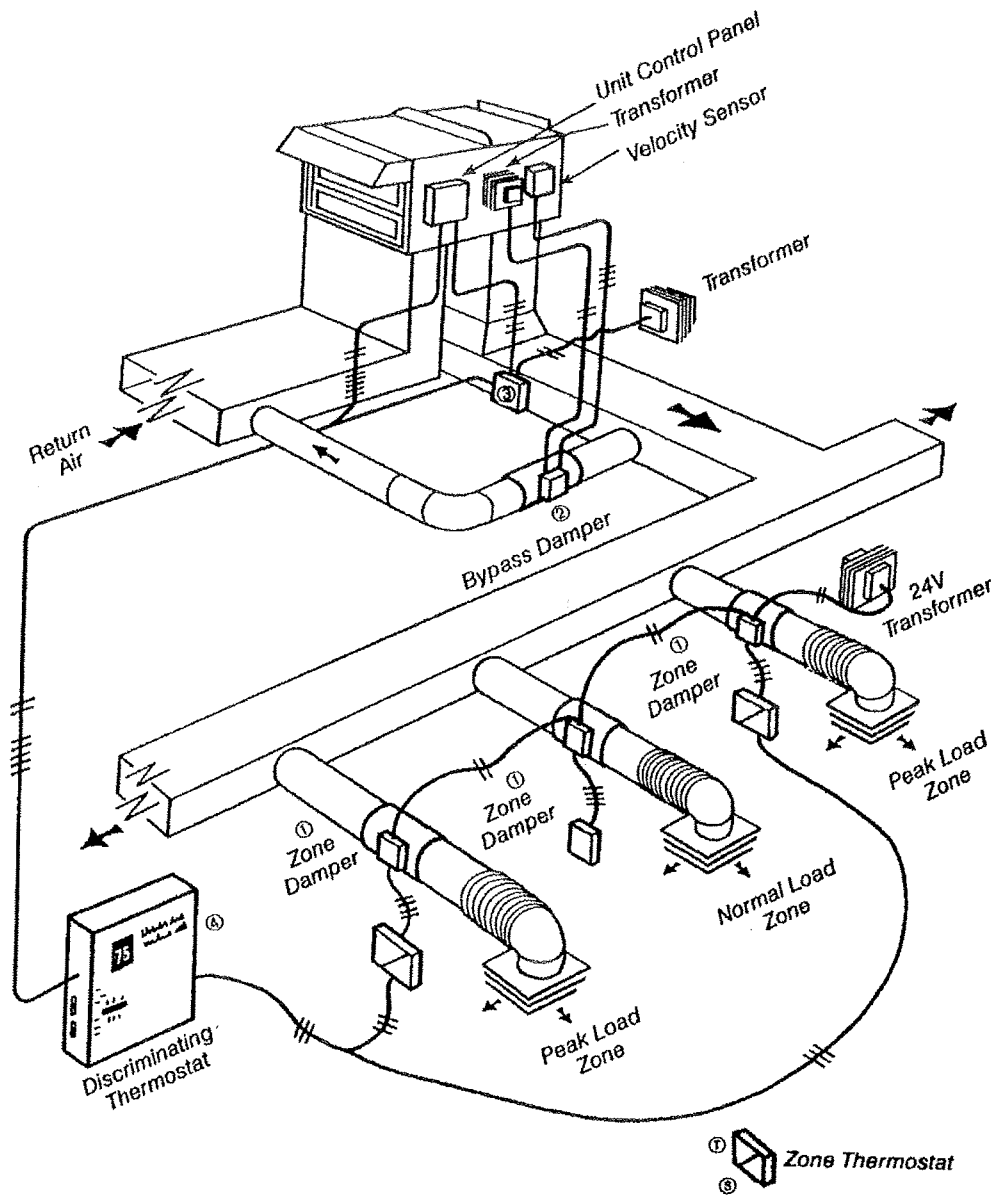

Figure A-1. Modulating Zone Control System.

Source: OMNIZONE, Huntington Beach, CA. Used with permission.

The following three examples illustrate applications of this system in different types of facilities and spaces.

### Application 1

Problem: A business contains a large showroom and smaller individual offices. Individual offices might overheat and overcool.

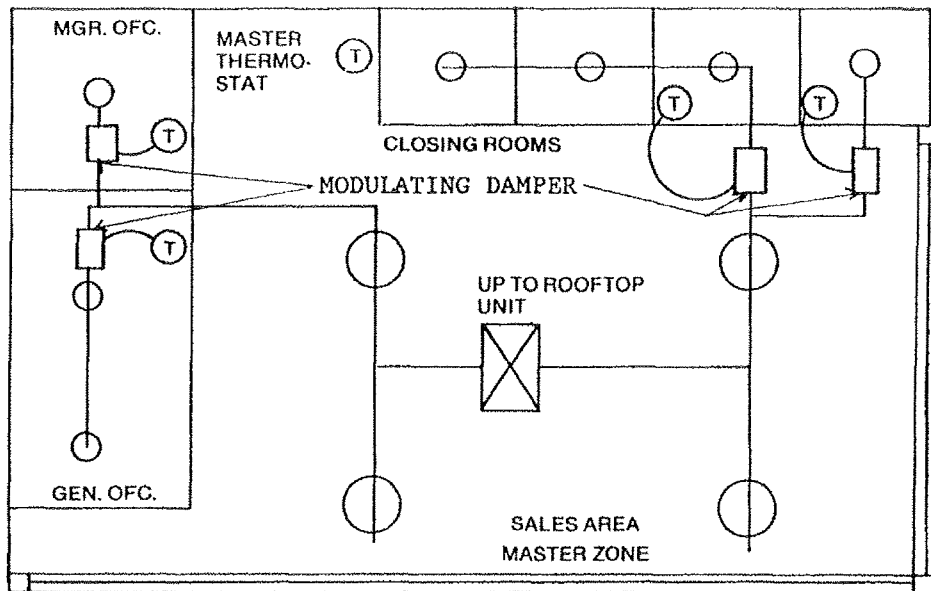

Solution: Master-submaster (partial zoning) cooling/heating system.

1. Set up duct system to supply air to master zone.
2. Take branch ducts to each subzone (the individual offices).
3. Install dampers on each branch duct.
4. Install thermostat in each subzone to control damper.

Install air-conditioning unit thermostat in master zone.

Operation: With the air-conditioning unit on, air will be supplied to all diffusers. As the individual offices start to be conditioned, the units will modulate to match exact room load. Excess air not required in these subzones will be shunted to the master zone. When the thermostat in the master zone is satisfied, it will shut down the refrigeration system or step out one compressor on two compressor systems. The process is similar for heating.

### Application 2

Problem: Medical building with many zones, each of which vary in occupancy and load.

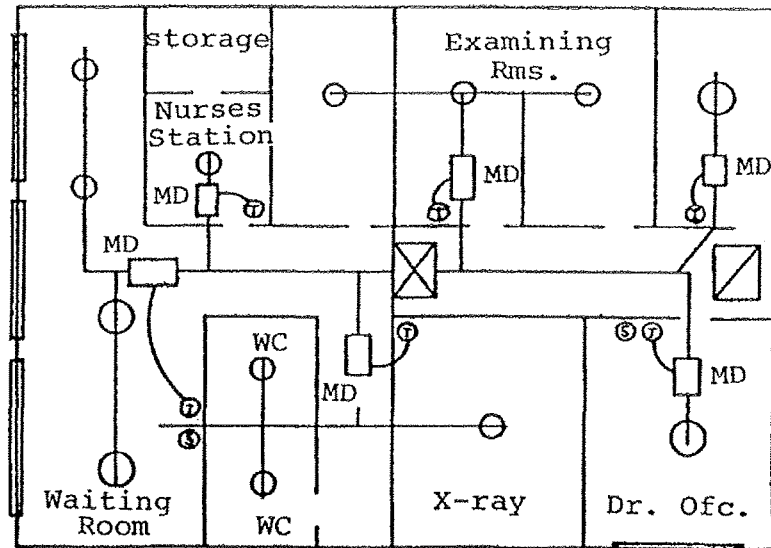

MD - Modulating Damper

↑ N

- Solution:
1. Select and install air-conditioning/heating unit to match block load.
  2. Select and install bypass unit (50% of fan cfm).
  3. Select convenient location for discriminator. Select sensor locations as required to monitor major loads. In this application, a sensor in the waiting room because of large west glass load and highly variable population load, and a sensor in the doctor's office because of its southeast glass load.
  4. Install duct system to supply proper air quantity to each zone.
  5. Install dampers in duct system to control air delivery to each zone.
  6. Install thermostats in each zone.

**Operation:** With the discriminator set for 75 °F, the system will operate as follows. When the temperature at any zone sensor is above the set-point, the air-conditioning unit will operate in the cooling mode. Cooling will continue to operate until all zone sensors are below 75 °F. While cooling is being supplied, each zone thermostat can control its own damper to maintain the temperature required in that zone. When all sensors are at or below 75 degrees, the discriminator will operate the system to provide ventilation. When there are no calls for cooling, and temperature at one of the sensors falls to 70 °F, the discriminator will turn on heating. Heating will operate until all sensors are at or above 70 °F, or a critical zone is again calling for cooling. During heating operation, all zone thermostats will change to the heat mode. Any zone requiring heat can be wide open. Zones with less demand will modulate to maintain the desired zone temperature. As the zone dampers modulate, fan capacity is controlled by the bypass. Compressor capacity is controlled by the leaving air temperature sensor. In this way, a variety of zone requirements can be satisfied by one air conditioning unit.

### ***Application 3***

**Problem:** Long building with east/west exposure. Constant volume units are a problem because one thermostat cannot furnish adequate control. As the sun's path crosses from east to west, the load of the building will follow. A system must provide adequate and cost-efficient air conditioning for the separate parts of the building as the load shifts.

**Solution:** Using the MZCS will take advantage of diversity. The system will follow the sun and shift air to the side of the building with the maximum load.

1. Select air-conditioning units to match block load of building.
2. Design duct system to supply proper air quantity to each zone.
3. Select modulating dampers for each zone.
4. Select thermostat locations for each modulating damper.



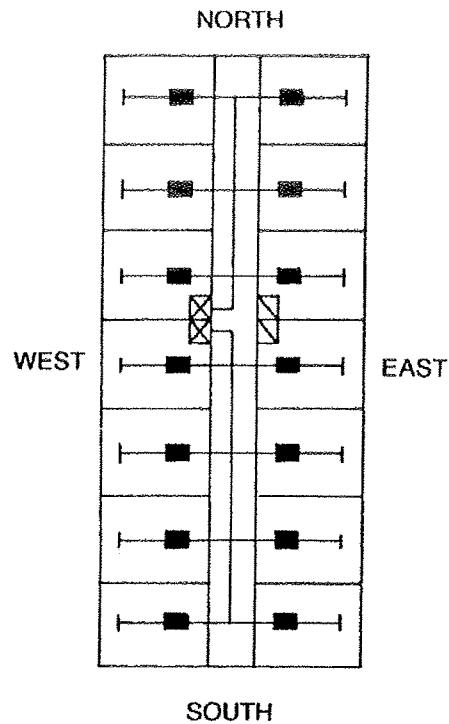

5. Select bypass damper for 50 percent of unit cfm.
6. Select locations for discriminator sensors to monitor major east/west loads.

Operation: With the discriminator set for 74 °F and sensors installed on the east and west sides of the building, the discriminator will first satisfy a demand for cooling from any sensor with a temperature higher than 74 °F. The dampers will reduce air delivery to zones with lower demand for cooling. As the load shifts from east to west, the discriminator sensors will operate the package unit, and the dampers will modulate airflow to maintain required room temperatures. As the zone dampers modulate, the bypass will provide constant air volume through the unit.

Using this system of control and taking advantage of shifting sun load, the building air conditioning system can be sized around its block load rather than the sum of the peak loads.

## 2 Air Handling Units

VAV terminals provide conditioned air to a zone or space. Conditioned air to the VAV terminals come from air handling units typically located in a building's mechanical room. The following sections describe the basic components that are normally found in air handling units.

### Basic Fan Types

Two types of fans are generally used in HVAC work: centrifugal and axial. Centrifugal fans are most commonly used in VAV systems, particularly the forward curved and airfoil types.

#### *Centrifugal Fans*

With centrifugal fans, airflow is perpendicular to the shaft and induced by the wheel. The forward curved (FC) centrifugal fan (Figure A-2) travels at relatively low speeds and is used for producing high volumes at low static pressure. The fan will surge, but the magnitude is less than for other types. Another advantage is that it has a wide operating range. The low cost and slow speed of the FC fan are additional advantages that minimize shaft and bearing size. One disadvantage is the shape of its performance curve. It could allow overloading of the motor if system static pressure decreases. It has an inherently weak structure, and therefore is not generally capable of the high speeds necessary for developing higher static pressures.

The airfoil fan (AF) (Figure A-3) is another type of centrifugal fan. It travels at about twice the speed of the FC fan. Generally, the larger the fan, the greater the efficiency. The magnitude of the AF fan's surge is also greater than that of the FC fan. Its higher speeds and bearing sizes, along with nonoverloading brake horsepower (BHP), allow higher efficiency but make proper wheel balance more critical. Also, as block-tight static pressure is approached, unstable operation may occur.

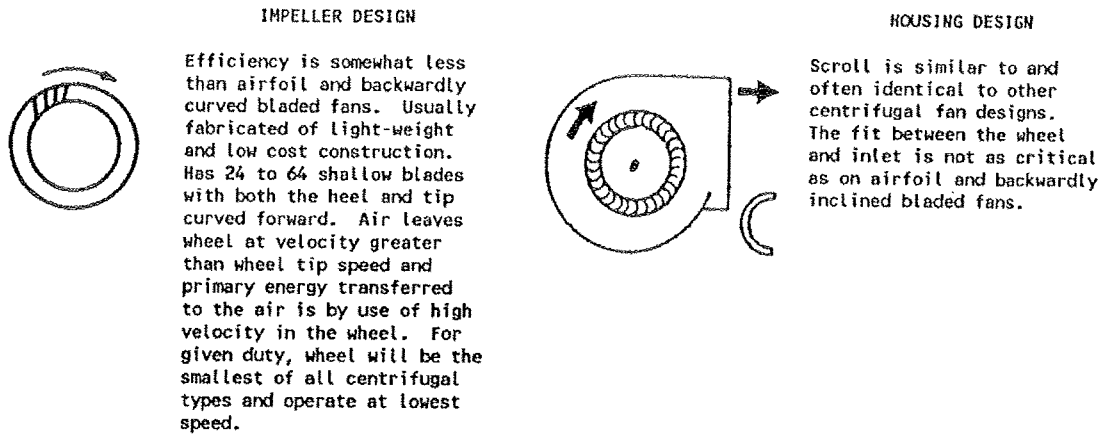

**Figure A-2. Forward Curved Centrifugal Fan.**

Reprinted with permission from the 1992 *ASHRAE HVAC Systems and Equipment Handbook*.

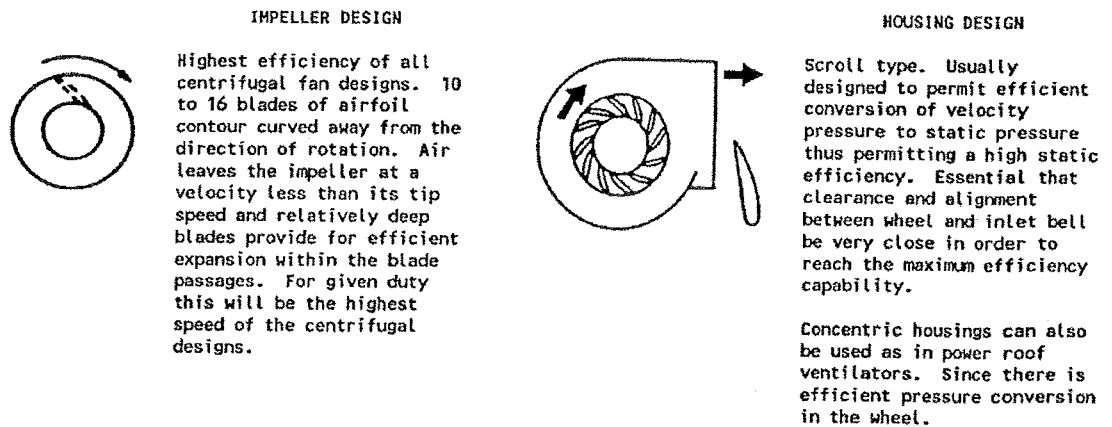

**Figure A-3. Airfoil Centrifugal Fan.**

Reprinted with permission from the 1992 *ASHRAE HVAC Systems and Equipment Handbook*.

Two additional types of centrifugal fans are the backwardly curved or backwardly inclined fan (Figure A-4), and the radial tip or radial blade fan (Figure A-5).

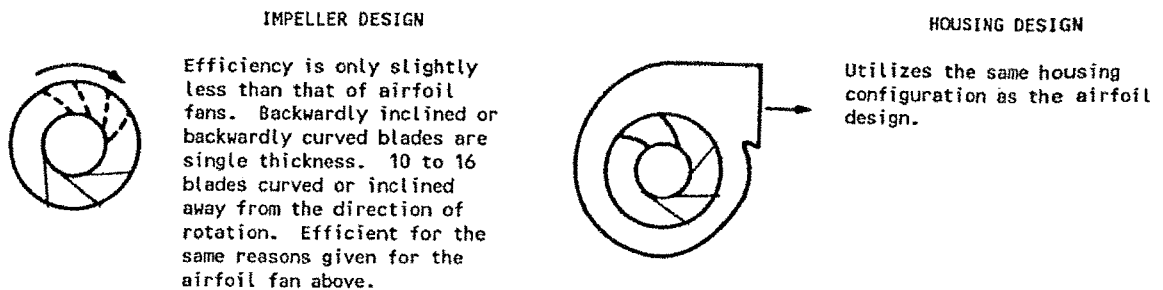

**Figure A-4. Backwardly Curved or Backwardly Inclined Centrifugal Fan.**

Reprinted with permission from the 1992 *ASHRAE HVAC Systems and Equipment Handbook*.

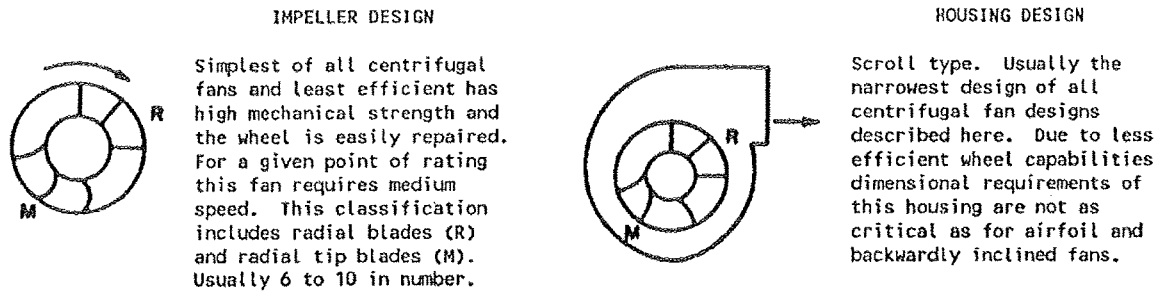

Figure A-5. Radial Tip or Radial Blade Centrifugal Fan.

Reprinted with permission from the 1992 *ASHRAE HVAC Systems and Equipment Handbook*.

Forward curved fans are stable and economical, but airfoil fans are better for discharging air into a plenum, and for multizone units and others having higher pressure through the system. The airfoil fan requires about 75 to 80 percent wide open volume, but the maximum BHP of the forward curved blade wheel is 100 percent wide open. This is a disadvantage for systems with large pressure fluctuations. Since fans operate best at peak efficiency, it is important to choose their size properly for quiet performance. For static pressures above 2 in. w.g., the backward inclined and airfoil fan are used. Below 2 in. w.g., the forward curved fan is best as far as noise is concerned.

### Axial Fans

In axial fans, the airflow is parallel to the shaft. Axial fans include propeller (Figure A-6), tubeaxial (Figure A-7), and vaneaxial (Figure A-8).

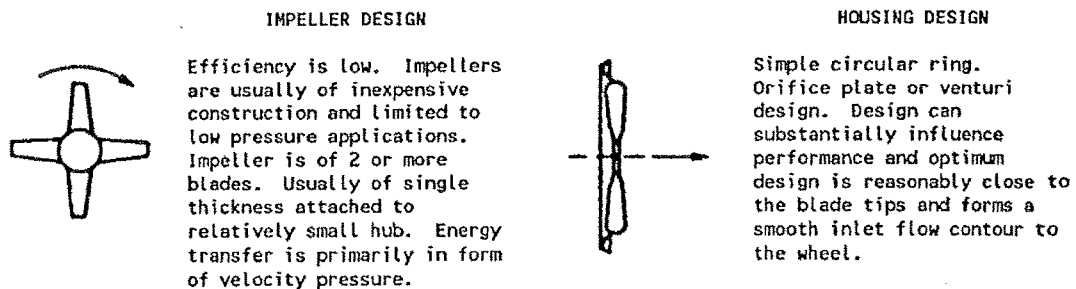
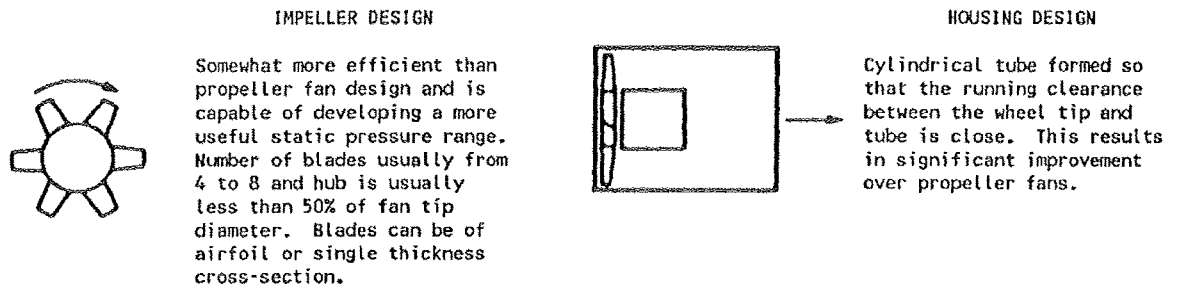

Figure A-6. Propeller Fan.

Reprinted with permission from the 1992 *ASHRAE HVAC Systems and Equipment Handbook*.



**Figure A-7. Tubeaxial Fan.**

Reprinted with permission from the 1992 *ASHRAE HVAC Systems and Equipment Handbook*.

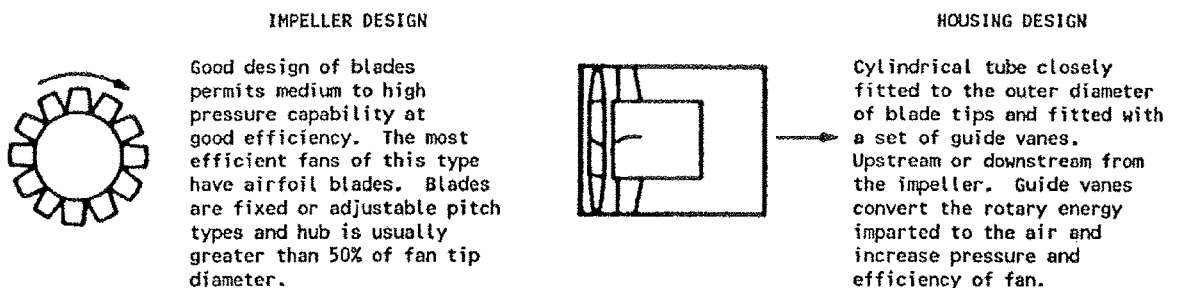
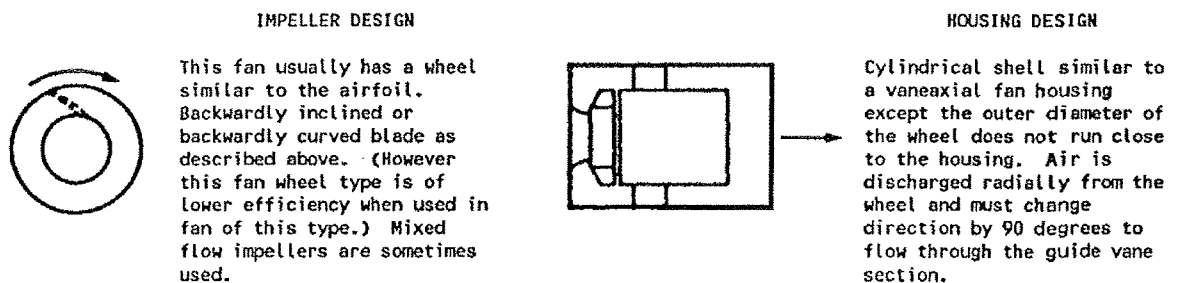

**Figure A-8. Vaneaxial Fan.**

Reprinted with permission from the 1992 *ASHRAE HVAC Systems and Equipment Handbook*.

**Other Fan Types**

Two additional fan types that may be encountered are the tubular-centrifugal fan (Figure A-9), and the inline centrifugal duct fan (Figure A-10).



**Figure A-9. Tubular-Centrifugal Fan.**

Reprinted with permission from the 1992 *ASHRAE HVAC Systems and Equipment Handbook*.

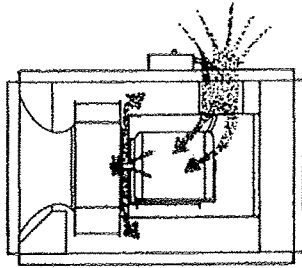

Superior aerodynamic performance is provided by deep venturi inlet combined with median-foil wheels. Casing sizes and internal baffling selected for optimum airflow. More air per dollar first-cost and more air per dollar of operating cost are provided by the high air handling efficiency. The same design details that produce maximum aerodynamic efficiency also assure quiet operation.

**Figure A-10. Inline Centrifugal Duct Fan.**

Source: Carnes Co., Verona, WI. Used with permission.

## Fan Classes

Fans are classified according to certain construction features such as thickness of metal, type of bracing, etc. Fan classification is usually shown in the manufacturer's performance data. The TAB technician should be aware of the fan classification as this will affect whether or not the operating conditions of the fan can be altered in order to balance the system.

## Fan Laws and Sizing

Shapes of performance curves for various fan types, and other information about static pressure, BHP, and rotations of the wheel per minute may be plotted on a fan curve (Figure A-11). Also, selection of fans to fit a system may be found by plotting on this curve.

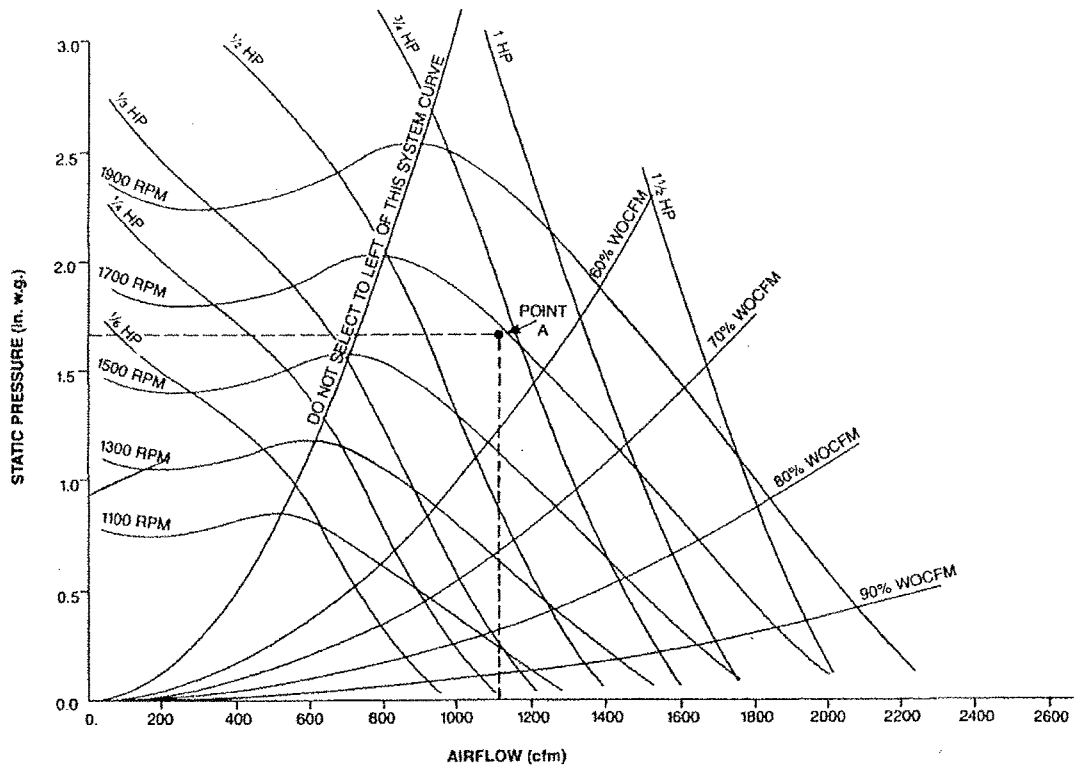

Figure A-11. Typical FC Fan Curves.

The following examples demonstrate applications of fan laws.

Fan Laws:

$$\frac{Q_2}{Q_1} = \frac{rpm_2}{rpm_1} \quad \frac{bhp_2}{bhp_1} = \left(\frac{rpm_2}{rpm_1}\right)^3 \quad \frac{P_2}{P_1} = \left(\frac{Q_2}{Q_1}\right)^2$$

where: Q = airflow (cfm)  
 rpm = revolutions/minute  
 P = system pressure (in. w.g.)  
 bhp = brake horsepower

Example 1:

A fan must be speeded up to supply 13,000 cfm. The airflow is presently measured at 10,000 cfm at 2.0 in. w.g. static pressure. What will be the new fan speed, if the present fan speed is 660 rpm?

From  $\frac{Q_2}{Q_1} = \frac{rpm_2}{rpm_1}$  then  $rpm_2 = 660 \times \frac{13,000}{10,000} = 858 rpm$

Example 2:

A duct system is operating at 2.0 in. w.g. with an airflow of 10,000 cfm. If the airflow is increased to 13,000 cfm without any other change, what is the new duct system pressure?

From  $P_2 = P_1 \times \left(\frac{Q_2}{Q_1}\right)^2$  then  $P_2 = 2.0 \times \left(\frac{13,000}{10,000}\right)^2$

$P_2 = 2.0 \times (1.3)^2 = 3.38 in. w. g.$

From the fan curve in Figure A-12, 3.38 in. w.g. of static pressure at 13,000 cfm requires an estimated 860 rpm. (When using this equation, the system pressure can be in terms of either total pressure or static pressure.)

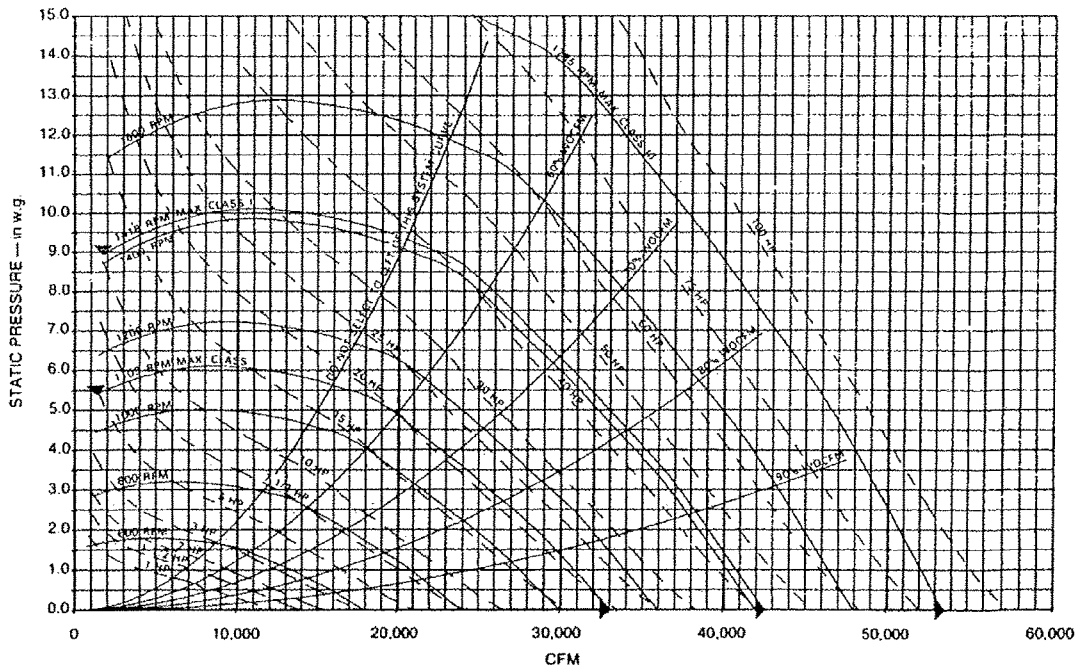

Figure A-12. Fan Curves.



Example 3:

The same system used in Example 2 has a 5 HP motor operating at 4.0 bhp. Find the bhp that would be required if the airflow was increased to 13,000 cfm.

$$\text{From } bhp_2 = bhp_1 \times \left(\frac{Q_2}{Q_1}\right)^3 \quad \text{then } bhp_2 = 4.0 \times \left(\frac{13,000}{10,000}\right)^3$$

$$bhp_2 = 4.0 \times (1.3)^3 = 8.79 \text{ bhp}$$

The 5 HP motor would be inadequate, and a 10 HP motor would be required.

The next three examples show how fans are sized. Before proceeding further, some terms used in the examples will be defined first:

SP    Static Pressure:                    The normal force per unit area that would be exerted by the moving air on a balloon immersed in it if it were carried along by the air.

ISP    Internal Static Pressure:        The sum of the pressure drops across components inside air handling units such as filters, cooling and heating coils, hot and cool deck dampers, etc.

ESP    External Static Pressure:        The sum of the pressure drop across components external to the air handling unit such as terminal boxes, elbows, diffusers, volume dampers, and all other friction causing elements in the duct system.

SPs    Static Pressure (suction)

SPd    Static Pressure (discharge)

ISPcc   Internal Static Pressure (cooling coil)

ISPhc   Internal Static Pressure (heating coil)

ISPF    Internal Static Pressure (filters)

$$\text{Fan SP} = \text{SPd} - \text{SPs}$$

#### Example 4: Single Zone Exhaust System

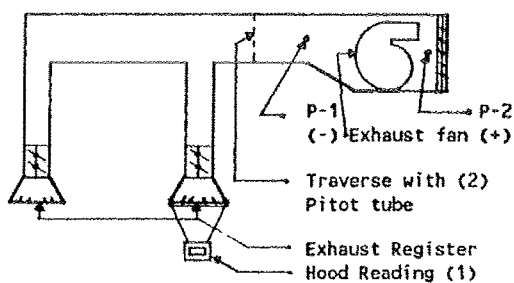

Find:

1. P-1 Neg. (Pressure required to move air from face of exhaust grill to P-1.)
2. P-2 Pos. (Pressure required to move air through discharge louver. P-2 will be 0 in. w.g. depending on discharge configuration.)
3. cfm (Determined by hood reading at exhaust grill and pitot tube traverse.)
4. Static Pressure (Taken with pitot tube.)
5. Fan Horsepower

$$P-1 = \text{SPs} = -.64 \text{ in. w.g.}$$

$$P-2 = \text{SPd} = .44 \text{ in. w.g.}$$

$$\text{Fan SP} = \text{SPd} - \text{SPs} = .44 - (-.64) = 1.08 \text{ in. w.g.}$$

From hood and pitot tube readings, cfm was found to be 6,509

By interpolation on Table A-1, fan bhp = 2.47.

Table A-1. Fan Ratings.

VOL. CFM	OUT VEL. FPM	VEL. PRES. IN. A.W.G.	0.125		0.250		0.375		0.500		0.625		0.750		0.875		1.000		1.250		1.500		1.750		2.000			
			RPM	BHP	RPM	BHP	RPM	BHP	RPM	BHP	RPM	BHP	RPM	BHP	RPM	BHP	RPM	BHP	RPM	BHP	RPM	BHP	RPM	BHP	RPM	BHP	RPM	BHP
2264	800	0.04	398	0.10	456	0.15	507	0.21	557	0.26	608	0.32	656	0.40	703	0.47	747	0.55										
2547	900	0.05	434	0.13	487	0.19	536	0.25	578	0.30	624	0.37	669	0.44	712	0.51	756	0.60	835	0.78								
2830	1000	0.06	472	0.17	519	0.23	565	0.29	608	0.36	645	0.42	686	0.49	727	0.57	767	0.65	843	0.83	916	1.00						
3113	1100	0.08	510	0.21	552	0.27	595	0.34	636	0.42	675	0.49	708	0.56	745	0.63	782	0.71	855	0.89	924	1.10	991	1.31				
3396	1200	0.09	549	0.26	587	0.33	627	0.40	666	0.48	702	0.56	738	0.64	768	0.71	802	0.79	870	0.97	936	1.17	999	1.39	1062	1.63		
3679	1300	0.11	588	0.32	624	0.39	661	0.47	697	0.55	731	0.64	765	0.73	798	0.81	825	0.89	889	1.07	950	1.26	1012	1.48	1070	1.71		
3962	1400	0.12	628	0.38	662	0.46	695	0.54	729	0.63	762	0.72	794	0.81	826	0.91	856	1.01	909	1.17	967	1.37	1026	1.56	1083	1.82		
4245	1500	0.14	668	0.46	700	0.54	730	0.62	762	0.72	794	0.81	825	0.91	854	1.01	884	1.12	936	1.30	988	1.50	1043	1.71	1097	1.94		
4528	1600	0.16	709	0.55	739	0.63	767	0.72	796	0.81	827	0.91	856	1.02	884	1.13	912	1.23	967	1.46	1013	1.64	1063	1.88	1114	2.08		
4811	1700	0.18	748	0.65	778	0.74	806	0.83	832	0.92	858	1.03	888	1.14	915	1.25	942	1.36	984	1.59	1044	1.82	1087	2.01	1134	2.25		
5094	1800	0.20	790	0.75	818	0.85	843	0.95	868	1.06	894	1.15	921	1.26	948	1.36	973	1.50	1023	1.74	1073	1.98	1115	2.21	1157	2.43		
5377	1900	0.23	830	0.86	857	0.96	882	1.06	906	1.16	930	1.25	955	1.40	980	1.53	1005	1.66	1053	1.90	1100	2.16	1146	2.42	1185	2.64		
5660	2000	0.25	872	1.01	897	1.12	921	1.23	944	1.33	966	1.44	989	1.56	1014	1.68	1038	1.81	1084	2.06	1129	2.34	1173	2.61	1217	2.89		
5943	2100	0.27	913	1.18	937	1.27	960	1.39	982	1.50	1004	1.61	1025	1.73	1048	1.85	1071	1.99	1116	2.28	1180	2.54	1202	2.82	1245	3.12		
6226	2200	0.30	954	1.32	977	1.44	999	1.56	1021	1.68	1042	1.80	1062	1.91	1083	2.04	1104	2.17	1148	2.46	1191	2.75	1231	3.04	1272	3.34		
6509	2300	0.33	995	1.50	1017	1.62	1039	1.75	1059	1.87	1080	1.99	1100	2.12	1118	2.24	1139	2.38	1181	2.67	1222	2.97	1262	3.28	1301	3.68		
6792	2400	0.36	1037	1.70	1057	1.82	1079	1.95	1099	2.08	1118	2.21	1137	2.34	1156	2.47	1176	2.60	1216	2.80	1266	3.20	1283	3.52	1331	3.84		
7076	2500	0.42	1120	2.13	1139	2.26	1158	2.40	1178	2.55	1196	2.68	1214	2.82	1231	2.97	1248	3.10	1284	3.40	1321	3.72	1358	4.06	1393	4.40		
7358	2600	0.49	1204	2.64	1221	2.78	1239	2.93	1257	3.06	1274	3.23	1291	3.38	1308	3.53	1324	3.69	1366	3.98	1399	4.32	1424	4.67	1459	5.03		
8490	3000	0.56	1287	3.23	1303	3.38	1320	3.53	1337	3.70	1353	3.88	1370	4.02	1385	4.18	1401	4.34	1431	4.67	1461	5.00	1492	5.36	1525	5.73		
9056	3200	0.64	1371	3.90	1386	4.05	1401	4.21	1417	4.39	1433	4.58	1448	4.74	1464	4.91	1478	5.06	1507	5.43	1535	5.77	1563	6.13	1593	6.51		
9522	3400	0.72	1455	4.56	1469	4.82	1483	4.99	1498	5.16	1513	5.35	1528	5.54	1542	5.72	1556	5.91	1583	6.23	1611	6.64	1637	7.00	1664	7.39		
10188	3600	0.81	1539	5.51	1552	5.68	1566	5.85	1579	6.04	1594	6.24	1608	6.43	1621	6.62	1635	6.82	1681	7.20	1697	7.69	1713	7.99	1737	8.37		
10754	3800	0.90	1623	6.46	1636	6.64	1648	6.82	1661	7.01	1674	7.21	1688	7.42	1701	7.63	1714	7.84	1740	8.35	1764	8.85	1788	9.06	1813	9.48		
11320	4000	1.00	1707	7.52	1719	7.70	1731	7.89	1743	8.09	1765	8.29	1789	8.52	1781	8.74	1794	8.95	1818	9.39	1841	9.80	1865	10.24	1888	10.68		

Pressure class limits:

Class	Maximum RPM
i	1550
ii	2140

## Example 5: Single Zone System

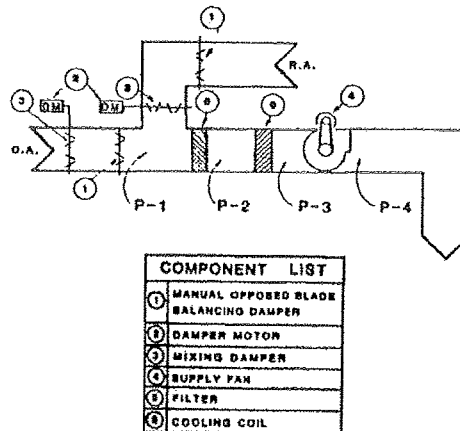

Find:

$$P-1 = \text{ESPs} = .53 \text{ in. w.g.}$$

ISPf and ISPcc: pressure drops available from manufacturer's data

$$P-2 = \text{ISPf} + \text{ESPs} = .08 + .53 = .61 \text{ in. w.g.}$$

$$P-3 = \text{ISPcc} + \text{ISPf} + \text{ESPs} = (-.18) + (-.08) + (-.61) = -.87 \text{ in. w.g.}$$

$$P-4 = \text{ESPd} = 1.15 \text{ in. w.g. (measured with pitot tube)}$$

$$\text{cfm} = 7,924 \text{ (determined by hood and pitot readings)}$$

$$\text{Fan SP} = (P-4) - (-P-3) = 1.15 - (-.85) = 2.00 \text{ in. w.g.}$$

From Table A-1, fan bhp = 5.03.

Example 6: Multizone System

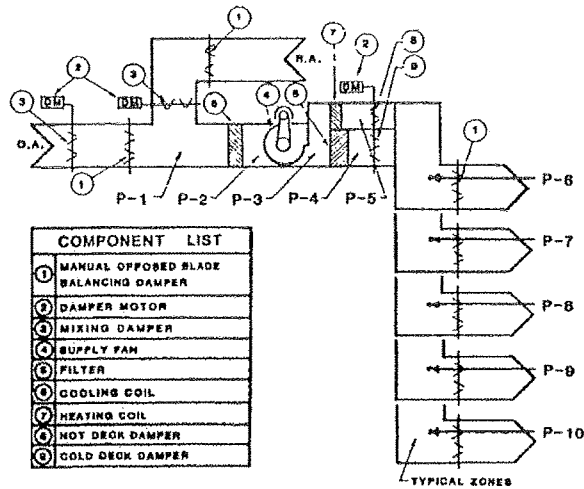

cfm = 10,188, amount of air required to supply zones 6-10

$$P-1 = -.40$$

$$P-2 = ISPF + (P-1) = (-.08) + (-.40) = -.48 \text{ in. w.g.}$$

$$P-3 = 1.15 \text{ in. w.g.}$$

$$P-4 = 1.15 - ISPcc = 1.15 - .15 = 1.00 \text{ in. w.g.}$$

$$P-5 = 1.15 - ISPhc = 1.15 - .05 = 1.10 \text{ in. w.g.}$$

In cooling mode (readings for P-6 through P-10 are obtained by pressure gauge measurements):

$$ESP_{sys6} = (P-4) - (P-6) = 1.0 - .32 = .68 \text{ in. w.g.}$$

$$ESP_{sys7} = (P-4) - (P-7) = 1.0 - .25 = .75 \text{ in. w.g.}$$

$$ESP_{sys8} = (P-4) - (P-8) = 1.0 - .30 = .70 \text{ in. w.g.}$$

$$ESP_{sys9} = (P-4) - (P-9) = 1.0 - .10 = .90 \text{ in. w.g.}$$

$$ESP_{sys10} = (P-4) - (P-10) = 1.0 - .20 = .80 \text{ in. w.g.}$$

$$FAN SP = (P-3) - (P-2) = 1.15 - (-.48) = 1.63 \text{ in. w.g.}$$

By interpolation on the fan rating table, fan bhp = 7.79.

The calculations show that P-9 has developed the largest static pressure required in the system. Therefore, fan size is based on the static pressure required at P-9, and use of the cooling coil (wet). All remaining systems require balancing with manual dampers.

### Fan Curves Vs. System Curves

System resistance curves or system curves are a plot of cfm vs. static pressure in a system. This shows a graphical representation of the system's resistance to air flow. Each system will have its own system curve that is represented by a single line. This curve will remain unchanged until there is a change to the system, such as dirt or moisture buildup, or a change in position of the outlet dampers.

When the system curve and a fan performance curve are plotted together, the intersection of the two curves will be the operating point of that system. The figure below shows a typical system curve plotted with two fan curves. This example illustrates the effects of a 10 percent increase in fan speed without a change to the system itself. The operating point moves upward along the system curve resulting in an increase in both cfm and static pressure.

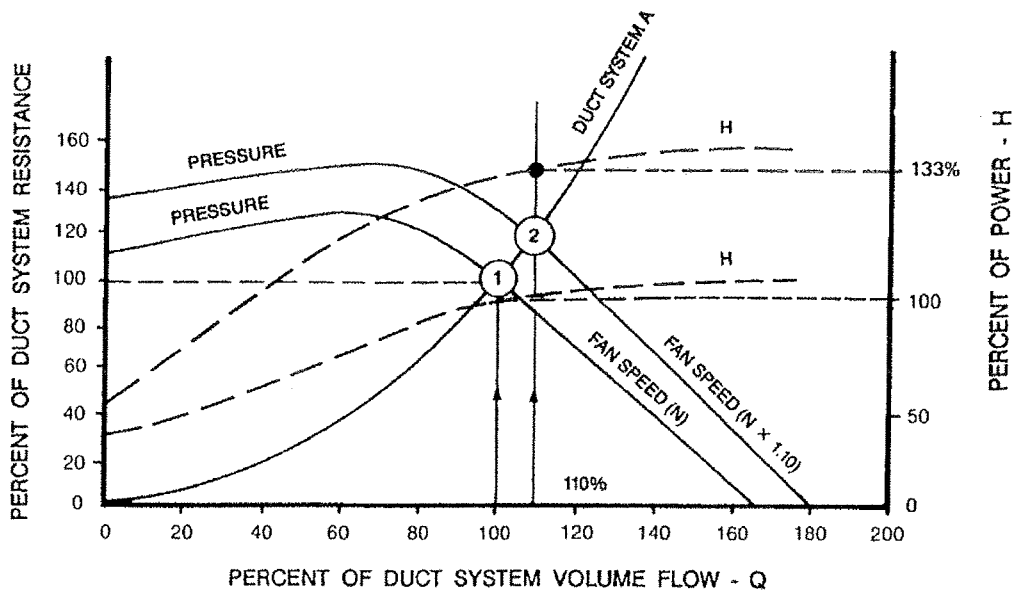

Figure A-13. Typical System Curve With Two Fan Curves.

Environmental Systems Technology, W. D. Bevirt, 1984. Reprinted with permission of the National Environmental Balancing Bureau.

However, if a change is made to the system that will shift the whole system curve to the right, the operating point will move downward along the fan curve. This results in an increase in cfm with less static pressure in the system.

The fan and system curves can be used to help troubleshoot different problems that may occur in the system. They can also be used to model the effects of different changes to the system or fan. This helps in predicting what changes will produce the best results. This method, however, does not produce exact results. Therefore, when searching for exact answers, the appropriate fan laws must be used.

### Fan Discharge Control

The four common methods of controlling the effects of any fan: (1) discharge damper control, (2) inlet vane control, (3) variable pitch control, and (4) speed control. Figure A-14 shows the approximate power savings that can be obtained by reducing air quantities for the four methods of capacity control.

From a power consumption standpoint, variable speed motors and blade pitch control are the most efficient. Inlet vanes save some power, while discharge dampers throttling at the fan save little. From a first-cost standpoint, dampers are the least costly. Inlet vanes and blade pitch control follow, with variable speed motors being the most expensive.

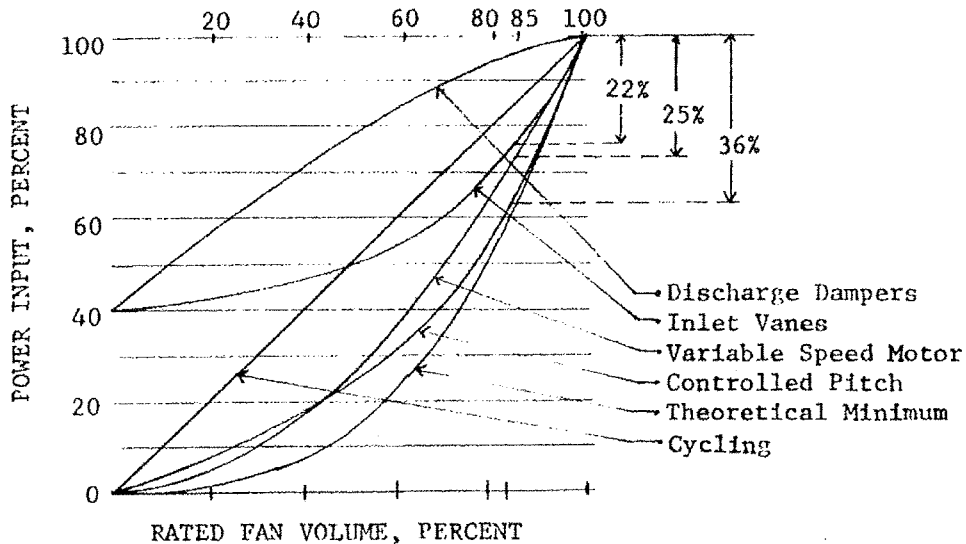

Figure A-14. Power Savings for Four Methods of Capacity Control.

### ***Discharge Air Dampers***

Discharge air dampers are installed to add resistance at the fan. The purpose of the discharge air damper arrangement is to create an excess pressure drop near the fan, thus permitting smaller pressure drops at the terminal units. The amount of air delivered to the terminal units depends on the pressure built up at the fan. When air delivery has to be reduced at the terminal unit, the terminal unit air dampers will throttle it down. It is impractical to have the terminal units serve as the sole means of throttling air supply. For example, terminal units should not have to throttle down 3 in. w.g. when all they were designed to throttle is 1 in. w.g. So, the pressure over and above what is actually needed at the terminal units is throttled down by the discharge air dampers before it even enters the rest of the system. Because of the initial throttling, there is less noise at the terminal units. With an initial pressure drop at the fan, there is more ductwork to aid in sound attenuation prior to discharge.

Sizing of discharge air dampers should be done with great care. There are many rules-of-thumb, but the recommended procedure is to size the discharge air dampers for a wide open pressure drop of from 7 to 10 percent of the system pressure.

Because discharge air dampers waste horsepower, they should not be used to control VAV systems if operational efficiency is desired. Figure A-11 shows that their efficiency is not adequate to warrant their use for economic operation purposes.

### ***Variable Inlet Vanes***

The most commonly used method of controlling fan capacity on VAV systems is variable inlet vanes. Inlet vanes, often referred to as pre-rotation vanes, cause the air to swirl before it encounters the fan wheel. The fan wheel cannot "grip" the air as well and consequently, capacity is reduced more efficiently than with discharge damper control. Excess pressure is not created and wasted. Figure A-15 shows examples of an inlet vane type system. The fan inlet vanes are positioned by an actuator in response to a signal received from the system static pressure receiver-controller.



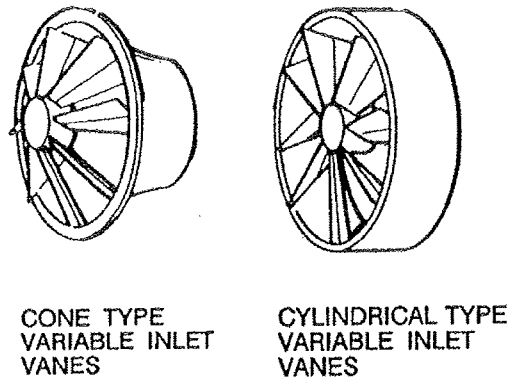

**Figure A-15. Examples of Inlet Vane System.**

Modification from AMCA, Publication 201-90. Used with permission.

The static pressure transmitter, through the receiver-controller and actuator, repositions the inlet vanes to maintain a relatively constant duct pressure at the point of sensing. As the terminal unit dampers throttle, the characteristic curve (resistance curve) shifts. The static pressure transmitter senses this shift, and throttles the inlet vanes accordingly. The fan curve is shifted, and a new operating point is established. The new operating point will depend on where the terminal units that are being throttled are located in the system. Fan discharge pressure will not remain constant since the location of the pressure transmitter is at the end of the system.

Care must be exercised in selecting the fan. It is important for the fan to be able to be throttled to the near minimum flow required without becoming unstable. Systems that can be throttled to near shut-off must often be equipped with a fan bypass to permit a minimum flow through the fan at all times.

#### ***Variable Pitch Blades***

Variable pitch axial-flow fans deliver an amount of air in accordance with the pitch of the fan blades. As more or less air is needed in the system, an actuator positions the pitch of the fan blades accordingly. The positioning of the blades is similar to the positioning of the inlet vanes. However, the fan is always spinning while inlet vanes remain stationary. The degree to which the blades are pitched determines how much air can be “gripped” and passed on into the system.

#### ***Variable Speed Drives***

Various ways to control fan speed include variable speed motors, magnetic couplers, and fluid drive systems. Fluid drive units use hydraulic fluid for

transmitting power. Magnetic coupling models use interacting magnetic fields to transmit power. Another method is to use exhaust steam, when readily available, to drive the fan with a steam turbine. The most common method, however, is motor speed control.

Adjustable speed drives (ASDs) are devices that vary the speed of a motor to match the load being put on the motor. Many types of ASDs are available, including mechanical (eddy current drives, variable-ratio pulley, and hydraulic drives), direct current (DC motors), and electronic. Although mechanical drives and DC motors have been applied extensively in industrial settings, they are seldom used in commercial buildings for economic or technical reasons. The mechanical variable-ratio pulley is applicable to commercial buildings (from 5 to 125 horsepower), but space requirements and mechanical problems usually make commercial applications impractical. DC motors comprise a mature technology, but they are expensive and have a reputation for high maintenance costs. The electronic load-commutated inverter has also been used in industry, but it is not an energy-conscious choice for commercial buildings.

Frequency operated adjustable speed drives are most commonly used for variable fan speed control today. Fan motor speed control is accomplished by mechanically, electrically, or hydraulically varying fan rpm in response to the signal from the pressure transmitter in the system. The transmitter/receiver-controller arrangement varies fan speed to maintain a constant duct pressure at the transmitter.

## Heating and Cooling Coils

Heating and cooling coils are simply heat exchangers between a heating or cooling medium and the air stream. Heating mediums available for heating coils are steam, hot water, or electricity. Steam and hot water coils consist of banks of copper tubing surrounded by sheets of corrugated fins that guide the air toward the tubing to maximize the heat transfer surface in contact with the air. Figure A-16 is a four-row cooling coil with double-tube serpentine circuiting.

A boiler is required to produce the steam or hot water for these types of coils, which in turn requires piping from the boiler to the AHU. Thus, the steam or hot water coils are economical only for medium and large-size installations, and become a more and more attractive option as the number of AHUs served increases.

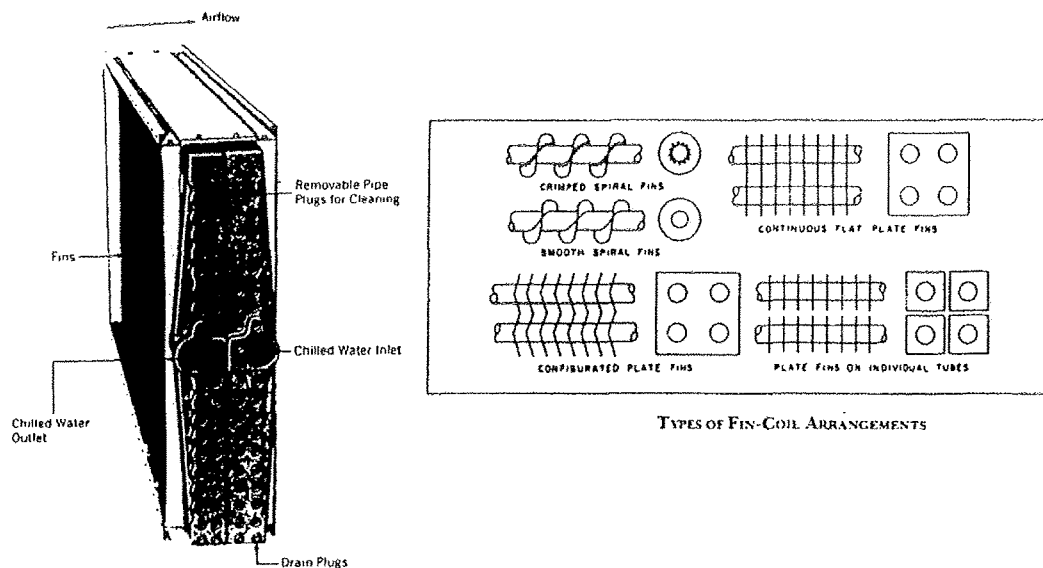

Four-row cooling coil with double-tube serpentine circuiting. (Courtesy The Trane Company, LaCrosse, Wis.)

**Figure A-16. Four-row Cooling Coil With Double-tube Serpentine Circuiting.**

A preheat coil is used to raise the outside air temperature to 55 °F before it gets to the AHU when the outside air is below 32 °F. Another special heating coil, known as a reheat coil, is sometimes placed downstream from the cooling coil for applications where humidity control is critical, such as in hospitals, laboratories, and some industries. The cooling coil dehumidifies the air to a precise point, and then the reheat coil warms it back up to the necessary temperature.

Cooling coils may carry either chilled water or refrigerant gas. The arrangement could consist of a single coil section or a number of individual coil sections built up into banks. The coil assembly will usually include an air cleaning means to protect the coil from accumulation of dirt, and to keep dust and foreign matter out of the conditioned space. Cooling coils for water or for volatile refrigerants most frequently have aluminum fins and copper tubes, although copper fins on copper tubes, and more rarely, aluminum fins on aluminum tubes are also used.\* The diameter of the tubes can vary from ¼ to 1 in. The fin spacing should be chosen for the duty to be performed, with special attention being paid to air

\* Approximately 90 percent of common HVAC coils are copper tube with aluminum fins due to cost, weight, and environment. There is always a difference in heat transfer between metals, but it is an insignificant amount.

friction, possibility of lint accumulation, and (especially at lower temperatures) the consideration of frost accumulation. The fins are generally spaced 3 per inch up to 14 per inch.

Coil capacity can be controlled without using a control valve. In Figure A-17, the face and bypass damper is actually two dampers linked together. When full heating (or cooling) is required, the damper section in front of the coil face is full open and the damper section in the bypass is shut. All the air passes through the coil. As the room demand for the coil capacity diminishes, a room thermostat signals a motor to move the face dampers toward the closed position while moving the bypass dampers to a more open position.

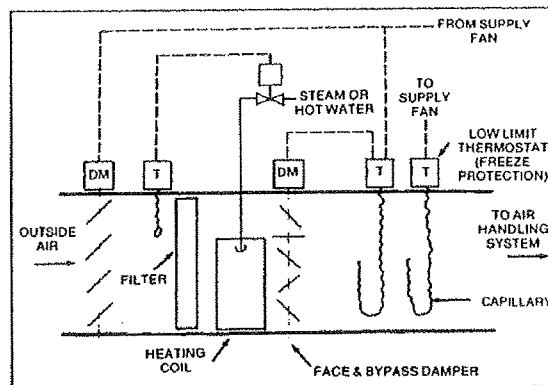

Figure A-17. Coil Capacity Controlled by Two Dampers Linked Together.

Reprinted with permission from the 1995 ASHRAE Applications Handbook.

### **Direct Expansion Coil Circuiting for Variable Air Volume Systems (DX/VAV)**

Direct expansion (DX) cooling coils are thermodynamically complex. Sensible and latent heat exchange occur on the inside and outside surfaces of the coils. Mixed or all outside air flowing across the coils is both sensibly and latently cooled; this causes moisture to condense on the coil surface. Inside the refrigerant tube (cooling coil), sensible and latent heating occur as refrigerant is evaporated, and superheated. Superheated vapor (refrigerant vapor) is characterized by the actual pressure of the vapor being lower than the saturation pressure at a given temperature, and the actual temperature of the vapor being higher than the saturation temperature of the vapor. Superheating occurs beyond the saturated vapor phase, and it is very important to keep the refrigerant in this superheated phase until it gets to the compressor. If a mix between saturated vapor and saturated liquid exists in the line prior to entering the compressor, liquid refrigerant will dilute compressor oil, robbing the compressor of vital lubrication.

If left in the compressor, liquid refrigerant can cause oil foaming when the compressor restarts, and foaming hampers delivery of oil to critical crankshaft and journal bearings.

Sensible and latent heat do not occur in a linear fashion along the outside of the coil surface, so the coil may not be uniformly wetted. On the inside surface, as liquid and vapor refrigerant (mix) are forced through the tube, a pressure drop results and lowers the refrigerant boiling point.

Chilled water gets warmer as it goes down the tubes, but the refrigerant actually cools in this process. Only after all the refrigerant is completely evaporated can superheating begin to warm the vapor. The point where superheating begins also affects the coil capacity and performance because it affects the pressure drop which is not always uniform.

Even though excellent refrigerant piping practices are followed in most installations of DX/VAV split systems, some systems become very unstable, especially at part load conditions. Some of the common problems that have occurred include erratic thermal expansion valves, continued compressor cycling, coil frosting, poor temperature control, and the return of liquid refrigerant to compressors. In some severe cases, compressors can be destroyed. Considering all of these problems, suppose a system was designed with identical equipment, employing similar controls and prudent piping and installation practices, and problems still occur, what separates good and poor DX/VAV systems? The difference could be the internal circuiting of the DX cooling coil.

A distributor is the device that uniformly transfers or distributes refrigerant from the thermal expansion valve to each circuit. There is only one distributor for each expansion valve. Since the expansion valve bulb senses the degree of superheat for all the circuits on that distributor, it is unaware of any differences between circuits. Therefore, the refrigerant must be distributed uniformly to all circuits.

When the distributor's maximum MBh/circuit is insufficient to meet design load, or minimum compressor loading is less than the distributor's minimum MBh/

circuit, the coil must be divided into separate sections or "splits."\* Each section is fed by one distributor.

The coil can be split in three ways to satisfy the needs of a specific design. This is where the engineer must use a knowledge of the environment in which the system will operate and select accordingly. Following is a brief description of each kind of split system and where they are best used. The three systems are horizontal or face split coils, vertical or row split coils, and intertwined coil circuiting (Figure A-18).

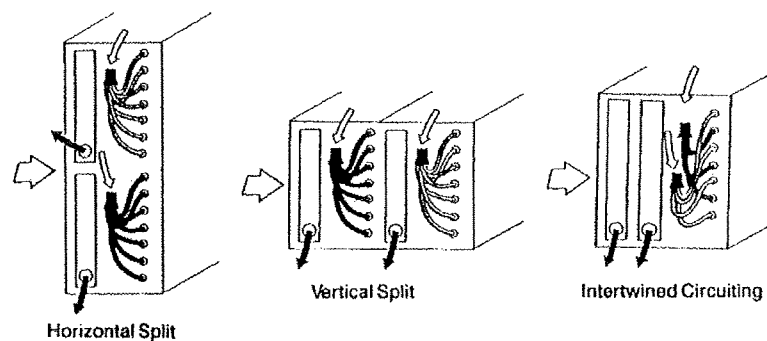

Figure A-18. Split Systems.

Source: *ASHRAE HVAC Systems and Equipment Handbook, 1992*. Used with permission.

**Horizontal split/face split coils.** Face splits are preferred for VAV applications as adequate superheat is assured for each coil section. This is true even at part load because all coil sections receive unconditioned air.

When the system changes to handle part load conditions, the mass flow rates decrease, and a solenoid valve upstream of one of the thermal expansion valves is closed. All the refrigerant now flows through the remaining distributor. With the horizontal split coils, the mass flow at the open distributor doubles, and it singly maintains loading above the minimum MBh/circuit. The inactive coil section bypasses unconditioned air that may cause problems for systems that use 100 percent outside air at part load. Face split coils are not recommended for 100 percent outside air applications in humid climates. At part load, this type of

\* The minimum mass flow rate at which the distributor can provide uniform distribution to all circuits is expressed as MBh/circuit, and is a function of suction pressure. The maximum MBh/circuit is a function of distributor geometry and suction pressure. Stable performance is assured only when full load and part load MBh/circuit remains within this allowable range.

split coil can pose a potential problem because the system controllers try to keep the coil leaving air temperature constant. With a major part of the coil inactive, the active coil section must cool air to very low temperatures to maintain 55 °F leaving air. For example, if entering air is at 80 °F and half the coil is inactive, the active coil section must cool to 30 °F to achieve an average discharge of 55 °F. These conditions are conducive to coil frosting, and liquid refrigerant being returned to the compressor.

**Vertical/row split coils.** This type of split coils is not recommended for VAV applications. Compressor cycling can occur in row split coils. This is not bad in itself because reciprocating compressors can be used and will tolerate the cycling. However, compressor cycling upsets superheat control. Excessive superheat hampers compressor motor and discharge valve cooling. In the absence of superheat, liquid refrigerant is returned to the compressor. Reciprocating compressors are designed to tolerate brief periods of liquid in the suction line, but the combination of reduced airflow and humidity, and sustained initial temperature difference causes the upstream two row coil to produce a colder than anticipated leaving air temperature. The colder temperature leaving the upstream coil can hamper the ability of the downstream coil to provide adequate superheat. This superheat loss can occur for an extended period of time. If the loss of superheat lasts longer than the cycle rate of the VAV discharge air temperature controller, the compressor will likely fail.

**Intertwined coil circuiting.** The pitfalls of row and face split coils can be avoided by using intertwined coil circuiting. It provides more active fin surface at part load, and improved superheat capabilities at all load conditions.

At part load, the coil behaves like a coil with substantially greater fin surface, but without the penalty of higher airside pressure drop. By increasing the active fin surface at part load, the potential for coil frosting is reduced while maintaining excellent dehumidification. Superheat is not lost at part load conditions, and stabilizes quickly after a change in compressor or capacity.

Intertwined coil circuiting may require additional distributors and thermal expansion valves in some circumstances, but the DX/VAV stability at part load is worth the additions. Intertwined coils are best for almost all DX/VAV split system applications. They have been used extensively in packaged unitary equipment including rooftop and self-contained air conditioners in VAV applications.

If intertwined coils are not suitable, face split coils are acceptable if used with some type of supply air reset at part load. The row split should be avoided in VAV applications, but they are preferred in 100 percent outside air applications.

## Filters

Filters are important for providing a comfortable and healthy air supply to the occupants, reducing dust deposits on room surfaces, and keeping interiors of HVAC system components clean. Filters and other air cleaning devices are available in four general types for four general purposes: (1) typical commercial filters to remove visible particles of dust, dirt, lint, and soot, (2) electrostatic filters to remove microscopic particles such as smoke and haze, (3) activated charcoal to destroy odors, and (4) ultraviolet lamps or chemicals to kill bacteria.

Both throwaway and cleanable filters are available. Throwaway filters are generally standard on smaller AHUs (less than 10,000 cfm). The standard commercial grade filters remove about 75 to 85 percent of the particles in the air. In hospitals and laboratories where a high degree of cleanliness is called for, high-efficiency filters are used.

Three different physical arrangements for filters in air handlers are flat, offset, and V-bank. The latter two provide more filter face area and, therefore, a lower face velocity across the filter. The maximum allowable face velocity for throwaway filters is 300 fpm versus a maximum of 500 fpm for cooling coils and 800 fpm for heating coils.

Filter banks may contain many throwaway filters that slide into the filter section channels on the top and bottom of each row of filters. The easiest way to change filters in large systems is to open access doors on each end of the filter bank. New filters are pushed into one end, while the used filters fall onto the floor at the other end. When the filter bank is accessible from only one end, a strip is used in the bottom channel. As the strip is pulled out, the farthest filter from the access door is pulled, pushing all the other filters in that line ahead of it (Figure A-19).



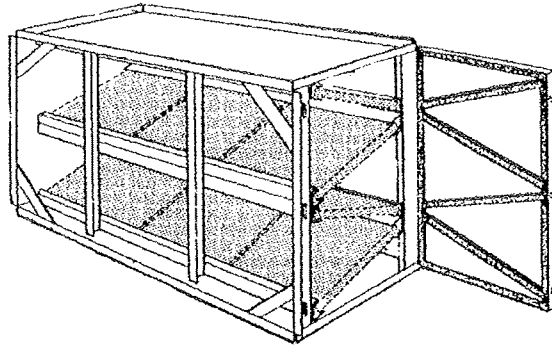
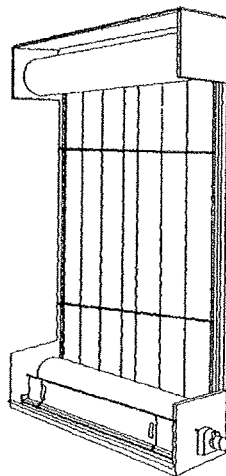

**Figure A-19. Changing Filters.**

Source: NAFA Guide to Air Filtration, 1993. Used with permission.

When dust loadings are expected to be quite heavy, the labor cost to continually replace filters can become prohibitive. Automatic filter changing can be done by using a roll filter (Figure A-20). The filter is advanced a few inches at a time, exposing new filter media at one end and rolling up dirty media at the other end. The advance of the filter is based on either a timer or a pressure-drop reading across the media. The latter is better because it exposes new media based on how much dirt the existing media has collected rather than on how long it has been in place.

For very critical jobs, a bag filter (Figure A-21) provides an extremely high cloth area, allowing the air to move through the filtering media very slowly. These are sometimes referred to as HEPA filters, which stands for high-efficiency particulate arrest. They are expensive to replace, and should be used with a less expensive throwaway filter upstream to filter out the larger size particulates.



**Figure A-20. Roll Filter Exposes Clean Media While Rolling Up the Dirty Media.**

Source: NAFA Guide to Air Filtration, 1993. Used with permission.

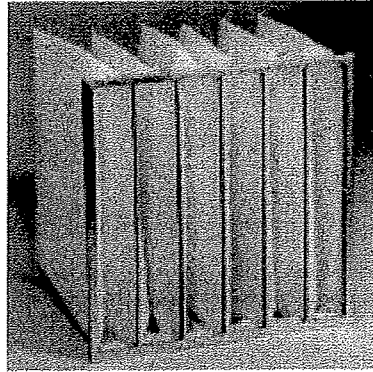

Figure A-21. Bag Filter Provides High Efficiency by Using Low Velocity Through the Filter Media.

Source: NAFA Guide to Air Filtration, 1993. Used with permission.

## Mixing Box

A mixing box section (Figure A-22) is a convenient way to bring return air and outside air into the air handler.

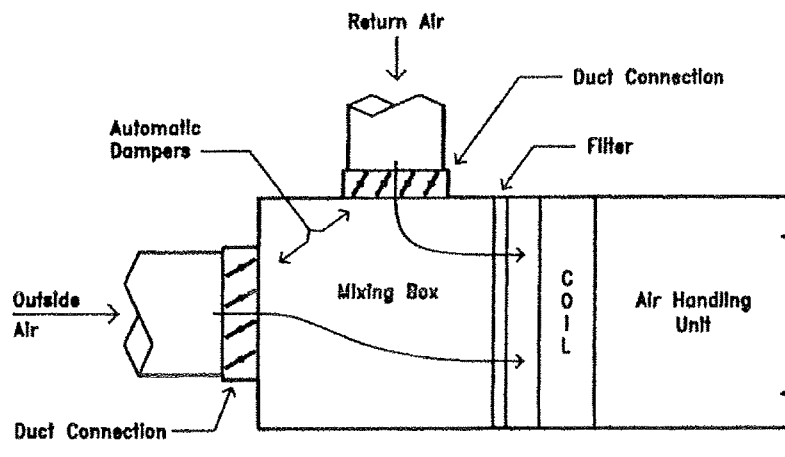

Figure A-22. Mixing Box for Return Air and Outside Air.

Source: Colen 1990. Used with permission of R.S. Means Company, Inc.

A damper is provided for each air stream to allow the controls technician to balance the percentage of outside air versus return air. The dampers may be either parallel blade or opposed blade (Figure A-23). Parallel blade damper sections are less expensive. Opposed blade damper sections provide better control characteristics.

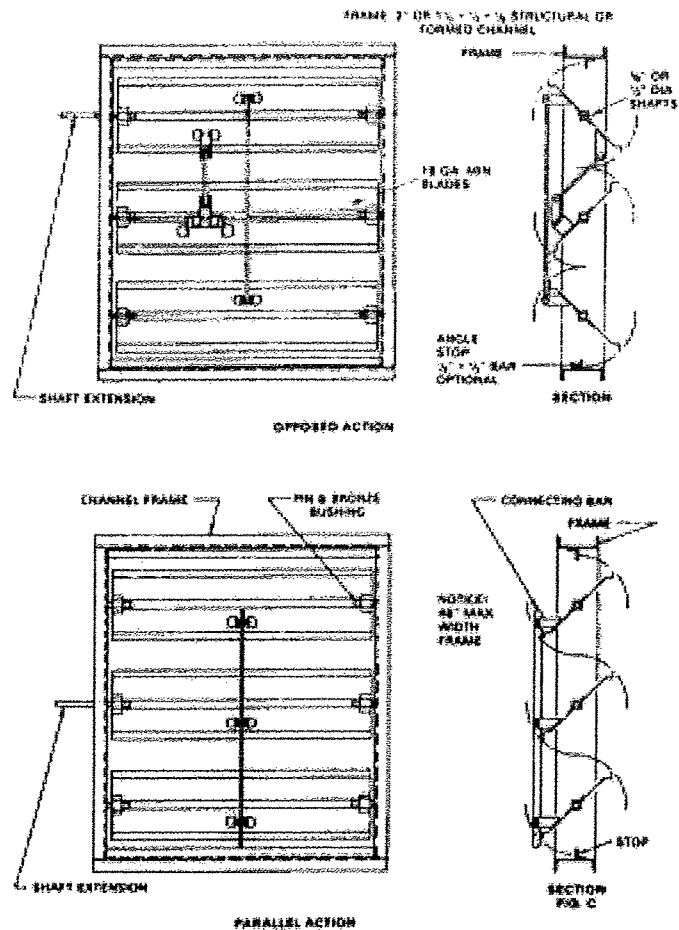

Figure A-23. Opposed and Parallel Blade Dampers.

SMACNA HVAC Duct Construction Standards - Metal and Flexible, 2<sup>nd</sup> Ed., 1995. Used with permission.

## Humidification

Air leaving the central system of a VAV system is usually at 55 °F. Placing a humidifier in the air handling unit just before the cooling coils in a draw through setup would defeat its purposes for humidification. The steam would condense and drip, causing puddles in the AHU. If it were a rooftop system, this could lead to more serious problems.

Most humidifiers should be placed at least 10 ft from the AHU, if even this close. Since the VAV system has cool air and uses VAV boxes that are obstructions, it is best to place a humidifier in the duct after these boxes.

Humidification can be accomplished by direct injection of steam into the air stream, vaporizing water from a pan by heating it, passing air through a moist porous pad, or by spraying water from a nozzle into the air stream.

An example of a humidifier is the single-tube or Mini-Bank\* multi-tube humidifier. These are specifically designed for application in hospital surgery rooms, intensive care units, delivery rooms, clean rooms, and where rapid steam absorption (in cool air) is required. If large ducts are used, the Maxi-Bank\* may be used as it has an instantaneous total absorption within three feet of the tube bank, in any air temperature, and up to 50 percent relative humidity.

For a more detailed discussion on humidification, please refer to the Appendix A Annex.

---

\* A commercial product of the "DRI STEEM" Humidifier Company, Hopkins, Minnesota.

### 3 Duct Design and Construction

Of the total cost of owning and operating a typical commercial building, maintenance and operation account for approximately 30 percent, while initial construction costs account for approximately 20 percent (SMACNA 1981). Some of the variables responsible for initial system cost are duct system material, system operating pressure, duct size and complexity, fan horsepower, sound attenuation, and space requirements. Of these, a major contributor to total building HVAC system annual energy cost is the energy demand of the fan distribution system. The fan energy cost can be minimized by reducing duct velocities and static pressure losses. This has a direct bearing on the system first cost, however, and could influence building cost as a result of using larger ductwork and equipment. It may also require more space and larger mechanical rooms.

Good duct design can result in first cost savings, substantial operating cost savings, and lower noise levels by minimizing and equalizing static pressure throughout the system. If the duct design is poor, additional costs may arise because designers tend to use pressure independent terminal controls and multiple point duct air pressure and airflow sensors for fan volume control, and extra controls may be needed to provide adequate stability.

Several general design and construction principles can be followed to control first costs and future operating costs:

- Use the minimum number of fittings possible. Most fittings are fabricated by hand, and the cost can be four to eight times that of straight section of duct.
- Consider the use of semi-extended plenums.
- Consider sealing ductwork to minimize air leakage. Sealing may allow equipment and ductwork sizes to be reduced.
- Use round duct where space allows, as round ductwork gives the lowest possible friction loss for a given perimeter.
- Maintain a rectangular duct aspect ratio as close to 1 to 1 as possible to minimize friction loss and cost.

The aspect ratio example in Table A-2 (based on 5000 cfm and 100 ft of duct) shows friction rates change as duct dimensions vary. The graphs in Figures A-24 and A-25 illustrate the installed and operating costs vs. aspect ratio.

Duct Dimensions		Duct Area			Metal Thickness			Duct Weight*	
Inches	Millimetres	Square Inches	Square Metres	Aspect Ratio	Gauge	Inches	Millimetres	Pounds per Foot	Kilograms per Metre
24 (diam.)	600 (diam.)	452	0.28	—	26	0.022	0.55	5.70	8.35
22 × 22	550 × 550	484	0.30	1 : 1	26	0.022	0.55	6.64	9.73
30 × 16	750 × 400	480	0.30	1.9 : 1	26	0.022	0.55	6.95	10.71
44 × 12	1100 × 300	528	0.33	3.7 : 1	22	0.034	0.85	13.12	19.21
60 × 10	1500 × 250	600	0.38	6 : 1	20	0.040	1.00	19.32	28.28
80 × 8	2000 × 200	640	0.40	10 : 1	18	0.052	1.31	31.62	46.29

\*Duct Weight Based on 2 in.w.g. (500 Pa) Pressure Classification, 4 foot (1.22 m) Reinforcement Spacing. (Weight of Reinforcement and Hanger Materials **Not** Included.)

**Table A-2. Friction Rate Vs. Aspect Ratio.**

SMACNA *HVAC Systems Duct Design*, 3<sup>rd</sup> Ed., 1990. Used with permission.

## Duct Pressure Classification

The fan in an air distribution system provides the pressure to the airstream to overcome the resistance to flow of the fan itself, ductwork, air control dampers, cooling coils, heating coils, filters, diffusers, sound attenuation equipment, turning vanes, etc. These various components, duct surface friction, and changes in airflow direction or velocity cause various changes in pressure to occur in the duct system.

Figure A-26 illustrates typical pressure changes that may occur in a duct system. At any cross-section, the total pressure (TP) is the sum of the static pressure (SP) and the velocity pressure (VP). For all constant-area straight duct sections, the static pressure losses are equivalent to the total pressure losses. The pressure losses in the straight duct sections are called friction losses. The pressure losses increase more rapidly in the smaller cross-sectional area ducts. When duct cross-sectional areas are reduced abruptly (such as at B) or gradually (such as at F), both the velocity and velocity pressure increase in the direction of airflow. The absolute values of both the total pressure and static pressure decreases. The pressure losses at these points are dynamic pressure losses. From point D to E, there is a large jump in static pressure. As mentioned above, SP and TP in straight duct sections will increase or decrease with equal magnitude. Notice also the level of TP and SP at the fan is equal to atmospheric pressure. This jump in TP and SP is a result of the change from a negative pressure (on inlet side of fan) to a positive pressure (on the discharge of the fan). Increases in the

duct cross-sectional areas (at C and G) cause a decrease in velocity and velocity pressure, a continuing decrease in total pressure, and an increase in static pressure caused by the conversion of velocity pressure to static pressure. This increase in static pressure is commonly known as static regain.

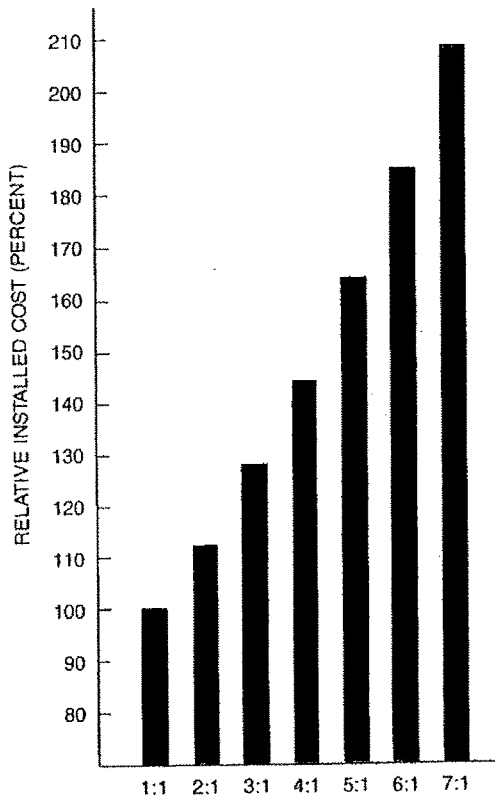

Figure A-24. Relative Installed Cost Vs. Aspect Ratio.

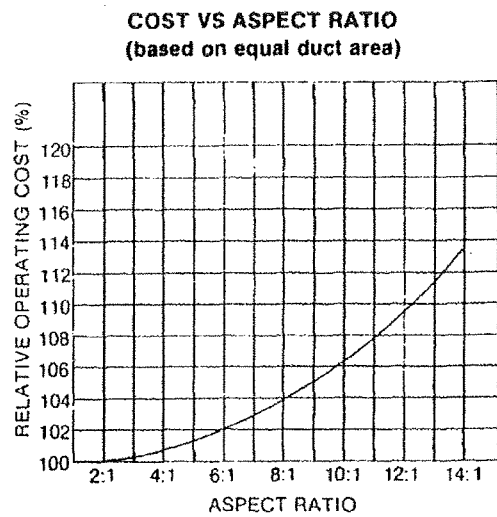

Figure A-25. Relative Operating Cost Vs. Aspect Ratio.

SMACNA HVAC Systems Duct Design, 3<sup>rd</sup> Ed., 1990. Used with permission.

All changes in the ductwork static pressure should be indicated on the drawings. In VAV systems, the pressure classification for the ductwork from the primary AHU to the mixing boxes is based on Table A-3 (SMACNA 1995).

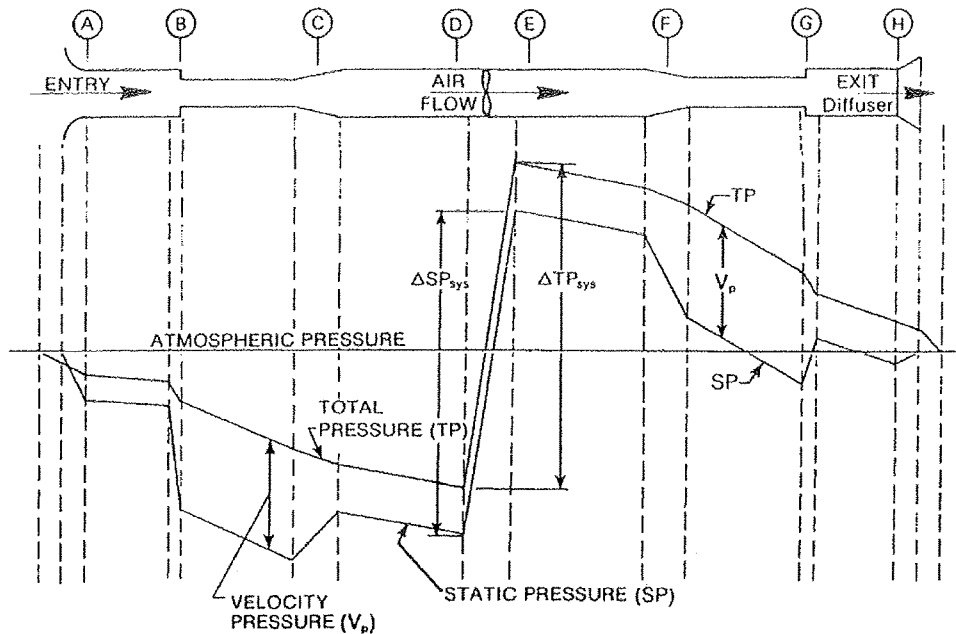

Figure A-26. Typical Duct System Pressure Changes.

SMACNA, *HVAC Systems—Testing, Adjusting and Balance*, 2<sup>nd</sup> Ed., 1993. Used with permission.

TABLE 1-1 PRESSURE CLASSIFICATION FOR DUCTWORK														
STATIC PRESSURE CLASS [INCHES (Pa) W.G.]	+1/2"	-1/2"	+1"	-1"	+2"	-2"	+3"	-3"	+4"	-4"	+6"	-6"	+10"	-10"
Rectangular Style	A	A	STD	STD	STV	A	A	A	A	A	A	A	A	A
Round Style					STV	STD			A	A			A	A
Flat Oval Style			STD		STV		A		A		A		A	
Flexible Style	A	A	STD	STD	STV		A		A		A		A	

Table A-3. Pressure-Velocity Classification for Ductwork.

SMACNA *HVAC Duct Construction Standards—Metal and Flexible*, 2<sup>nd</sup> Ed., 1995. Used with permission.

### General Approach to Duct Design

After room loads and air quantities have been determined, the next step is duct design. The type of duct system needed is determined based on an economic analysis of the building design and use.

The two main categories of air systems are single duct and dual duct. The single duct system uses a single path duct distribution system with a common (variable) air temperature to feed all terminal apparatus, or it blends air from hot



and cold sources within the AHU and uses a single duct to feed each zone. Dual duct systems use a separate cold and warm air duct distribution system that blends the air at the terminal apparatus.

After determining the type of duct system needed, duct design proceeds in the following order:

1. Locate air outlets and select size and type required for proper air distribution.
2. Locate return and exhaust air devices.
3. Select straightening vanes and dampers to be used with outlet devices to provide uniform face velocity and balancing.
4. Determine number of perimeter and interior zones.
5. Draw a preliminary schematic diagram for the ductwork that will provide the most efficient and economic path. Indicate the design airflows throughout the system.

### ***Locating and Selecting Outlets***

The number one concern in evaluating the air distribution in a space is the comfort of the occupants. The normal air velocity used for comfortable air distribution is 50 fpm while the acceptable range is from 25 to 75 fpm.

Outlets should be located to distribute the air as uniformly as possible throughout the room. Stagnant air is eliminated by an effective use of entrainment, which is the process by which the velocity of the air discharged from an outlet induces movement of the air already present in the room and blends the two.

In selecting outlets, keep in mind that cool air tends to drop away from the outlet, and warm air tends to rise to the ceiling. Select air outlets that provide acceptable air distribution for both cool and warm air.

The following order is followed for supply outlet location and selection:

1. Determine room supply air quantity from heating and cooling load calculations and design ventilation requirements.
2. Select type and quantity of outlets for each room and evaluate:
  - a. Outlet cfm
  - b. Outlet throw pattern
  - c. Building structural characteristics

- d. Aesthetic architectural requirements
  - e. Integration with other building systems, i.e. lighting, ceiling grids, partitions, etc.
3. Locate outlets to provide uniform room temperature using as uniform an air distribution pattern as possible.
  4. Select proper outlet size from manufacturer's catalog data considering:
    - a. Outlet cfm
    - b. Discharge velocity (throw)
    - c. Distribution pattern
    - d. Total pressure loss
    - e. Sound level.

Tables A-4 through A-6 provide a general guide for the proper selection of outlets based on design requirements of cfm per square foot and air changes per hour (SMACNA 1990).

Type of Outlet	Floor Space		Approximate Maximum Air Changes/Hour For 10 Ft. (3 m) Ceiling Height
	CFM/per Sq. Foot	l/s per Sq. Metre	
Grilles & Registers	0.6 to 1.2	3 to 6	7
Slot Diffusers	0.8 to 2.0	4 to 10	12
Perforated Panel	0.9 to 3.0	5 to 15	18
Ceiling Diffuser	0.9 to 5.0	5 to 25	30
Perforated Ceiling	1.0 to 10.0	5 to 50	60

**Table A-4. General Guide for Selecting Supply Outlet Type.**

SMACNA *HVAC Systems Duct Design*, 3<sup>rd</sup> Ed., 1990. Used with permission.

Group—Type	Mounting	Discharge Direction	Characteristics	
			Cooling	Heating
A High Sidewall Grilles Sidewall Diffusers Ceiling Diffusers Slot Diffusers (Parallel Flow) Variable Area Grille Variable Area Diffuser	Ceiling, High Sidewall  Ceiling, High Sidewall	Horizontal  Horizontal Specially adapted for variable volume systems	Good mixing with warm room air. Minimum temperature variation within room. Particularly suited to cooling applications  Maintain design air distribution characteristics as air volume changes	Large amount of stagnant air near floor. In interior zones where loading is not severe, stagnant air is practically non-existent  Maintain design air distribution characteristics as air volume changes
B Floor Grilles Baseboard Units Fixed Bar Grilles Linear Grilles	Floor, Low Sidewall, Sill	Vertical Non Spreading Air Jet	Small amount of stagnant air generally above occupied zone	Smaller amount of stagnant air than Group A outlets
C Floor Grilles Adjustable Bar Grilles Linear Diffusers	Floor, Low Sidewall, Sill	Vertical Spreading Air Jet	Larger amount of stagnant air than Group B outlets	Smaller amount of stagnant air than group B outlets—particularly suited to heating applications
D Baseboard Units Grilles	Floor, Low Sidewall	Horizontal	Large amount of stagnant air above floor in occupied zone—recommended for comfort cooling	Uniform temperature throughout area. Recommended for process applications
E Ceiling Diffusers Linear Grilles Grilles Slot Diffusers (Vertical Flow) Sidewall Diffusers	Ceiling, High Sidewall	Vertical	Small amount of stagnant air near ceiling. Select for cooling only applications.	Good air distribution. Select for heating only applications

Table A-5. Supply Air Outlet Performance.

SMACNA HVAC Systems Duct Design, 3<sup>rd</sup> Ed., 1990. Used with permission.

### **Locating and Selecting Returns and Exhaust Devices**

Return air inlets are generally located so that the room air returned is the greatest temperature difference from that being supplied to the room. Air motion is not significantly affected by the location of return and exhaust inlets. Also, the location of return and exhaust inlets will not compensate for ineffective supply air distribution. A return air inlet that is located directly in the primary air-stream of the supply outlet will short circuit the supply air back into the return without mixing with room air.

Special situations that require careful attention by the designer are the location of return and exhaust inlets in bars, kitchens, lavatories, dining rooms, club

Type	Characteristics	Applications
Fixed blade grille	Single set of vertical or horizontal blades	Long perimeter grille installations
Adjustable single deflection blade grille	Single set of vertical or horizontal adjustable blades	Sidewall installation where single plane air deflection is required
Adjustable double deflection blade grille	One set of vertical and one set of horizontal adjustable blades	Preferred grille for sidewall installation provides both horizontal and vertical air deflection
Stamped plate grilles	Stamped from single sheet of metal with square, round or ornamental designed openings	No adjustment of air deflection possible. Use for architectural design purposes only
Variable area grille	Similar to adjustable double deflection blade grille with means to effectively vary the discharge area	Use with variable volume system to minimize variation of throw with variable supply air volume
Curved blade grilles	Curved blades to provide horizontal air pattern	Ceiling installation High sidewall installation Perimeter installation
Perpendicular-flow slot diffuser	Generally 25 to 1 dimensional aspect ratio with maximum height of 3 inches (75 mm)	High sidewall installation Perimeter installation in sills, curbs and floors
Parallel-flow slot diffuser	Generally 25 to 1 dimensional aspect ratio with maximum height of 3 inches (75 mm)	Ceiling installation
Air light fixture slot diffuser	Use in conjunction with recessed fluorescent light fixtures with fixed or adjustable air discharge patterns	Ceiling installation— Order to match light fixture
Multi-passage round ceiling diffuser	Series of flaring rings or louvers forming series of concentric air passages	Install in center of area served
Multi-passage square and rectangular ceiling diffuser	Series of flaring rings or louvers forming series of concentric air passages	Install in center of area served
Adjustable pattern round ceiling diffuser	Series of flaring rings or louvers forming series of concentric air passages. Air discharge pattern adjustable from horizontal to vertical or down blow pattern	Install for control of diffuser discharge pattern or where specific requirement to direct airflow pattern either horizontal or vertical.
Adjustable pattern square and rectangular ceiling diffuser	Series of flaring rings or louvers forming series of concentric air passages. Air discharge pattern adjustable from horizontal to vertical or down blow pattern	Install for control of diffuser discharge pattern or where specific requirement to direct airflow pattern either horizontal or vertical.
Multi-pattern square and rectangular ceiling diffuser	Special louvers discharge air in one or more directions	Install in center of area served or adjacent to partitions. Set pattern according to flow requirements.
Half round diffuser	Matches round diffuser	Install in ceiling adjacent to partition or high sidewall
Supply and return concentric diffuser	Combination diffuser with return grille in center of diffuser	Install in center of area served
Light fixture air diffuser combination	Combination diffuser-light fixture	Ceiling installation combined with light fixture pattern
Perforated face diffuser	Perforated face plate with or without deflection device to obtain a horizontal discharge pattern	Install in center of area served or control discharge pattern when installed off center of area served
Variable area diffuser	Parallel or concentric passages or perforated face with means to vary discharge area	Use with variable volume system to minimize variation to throw with variable supply air volume
Air distributing ceilings	Ceiling system provided with round holes or slots	Use with ceiling supply plenum—particularly suited to large zones of uniform room temperature
Linear grille	Linear slot width 1/2 to 1 inch (12 to 25 mm), continuous length with adjustable airflow blades	Ceiling and perimeter with air deflection adjustable from 1-way horizontal to vertical to 2-way horizontal
Egg crate grille	Fixed square grid	Ceiling or sidewall (no pattern adjustment)
High capacity double deflection blade grille	One set vertical and one set horizontal adjustable blades. Blades are deep & wide spaced	High sidewall installation where high capacity and low discharge velocity are required
Drum louvers and adjustable high capacity diffusers	Adjustable direction core	High sidewall or ceiling installation, where directional and/or long throw required provides spot heating or spot cooling to areas of high load requirements

Table A-6. Supply Air Outlet Types.

SMACNA HVAC Systems Duct Design, 3<sup>rd</sup> Ed., 1990. Used with permission.

rooms, etc. These normally should be located near or at the ceiling level to collect the warm air "build-up," odors, smoke, and fumes.

Generally, the procedure for inlet selection and location is as follows:

1. Determine from design load calculations the quantity of room return air and the quantity of exhaust air.
2. Taking into consideration the following, select the type and quantity of inlets for each room.
  - a. Inlet cfm
  - b. Inlet velocity
  - c. Architectural requirements
3. Locate inlets to enhance room air circulation, and to remove undesirable air.
4. Using manufacturer's catalogs, select proper inlet size considering:
  - a. Inlet cfm
  - b. Inlet velocity
  - c. Total pressure loss
  - d. Sound level.

### ***Zoning***

If the designer is not given the number of different zones of temperature control, then he/she must determine the number of both perimeter zones and interior zones. Generally, the exterior zone will be divided into zones that will be determined by building exposure (north, east, south, or west exposure). These perimeter zones can be further subdivided into smaller control zones, depending on variations in internal load or a requirement for individual occupant control, such as a computer room, a conference room, or a private executive office. Likewise, the interior zones may also be broken down into control zones to satisfy individual office requirements or variations created by internal loads such as lights, people, or machinery.

### ***Preliminary Duct Layout***

After determining the zones for the building, a preliminary layout of the ductwork will need to be drawn. This diagram should indicate the design airflows throughout the system, and illustrate the most efficient and economic paths to the selected zones and outlets. It is suggested that this preliminary layout be drawn on a tracing of the architectural floor plans. This will help the designer coordinate the ductwork with the structural limitations of the building and other

services for the building. It will also enable the designer to have a good representation of the relationship of air terminals, branch ducts, main ducts, risers, etc.

### ***Duct Sizing***

Ductwork for HVAC duct systems usually is sized as round ductwork first. Then, if rectangular ducts are desired, duct sizes are selected to provide flow rates equivalent to those of the round ducts originally selected. If the rectangular duct sizes are calculated directly from the actual duct cross-sectional area, the resulting duct sizes will be smaller, causing a greater velocity and larger friction loss. The efficiency of duct fabricating machinery that reduces shop labor cost has encouraged a trend toward returning to the use of rectangular ductwork for high velocity systems. A disadvantage can be noise generated by turning vanes and balancing dampers. Most knowledgeable designers still feel that round spiral ducts can be used more expediently and may have more overall advantages.

Using one of the design methods discussed in the next section, the designer must select duct sizes and then calculate total pressure or static pressure losses. He/she will then need to determine if the ductwork will fit into the building. Consideration must be given to:

1. Additional space required beyond bare sheet metal sizes for reinforcing, circumferential joints, and hangers.
2. External insulation or duct liner.
3. Clearance for piping, conduit, light fixtures, etc.
4. Clearance for removal of ceiling tile.
5. Space requirement for air terminals, mixing boxes, pressure reducing boxes, fire and smoke dampers, reheat coils, etc.

### **Duct Design Methods**

Of several different design methods, the most universally used are the equal friction and the static regain methods. The following objectives and considerations should be adhered to for all methods:

- Design the duct system for the most efficient airflow from the fan to the terminal devices.
- Consider energy conservation in the fan selection, duct configuration, duct wall heat gain or loss, etc.
- Consider sound attenuation.

- Indicate the location of all life safety devices such as fire dampers, smoke dampers, etc.
- Make provisions for testing, adjusting, and balancing.
- Consider the pressure losses that occur from tie rods and other duct obstructions.
- Consider that round ducts are preferred on higher pressure systems due to their lesser construction costs.

### ***Equal Friction Method***

Probably the most widely used method of duct sizing is the equal friction method. It is used for sizing low pressure supply air, return air, and exhaust air systems. It is also being adapted by many for use in medium pressure systems.

Advantages:

- Requires less balancing for symmetrical layouts.
- Automatically reduces air velocities in the direction of airflow. This reduction will decrease the chances of introducing airflow generated noise from high velocities.
- System velocity may be readily checked at any point.
- Disadvantages:
- No natural provision for equalizing pressure drops in the branches.
- No means of providing the same static pressure behind each supply or return terminal device.

Procedure:

1. Select initial velocity in main duct near fan.
2. Using selected velocity and design cfm, determine the friction rate.
3. This same friction rate is then maintained throughout the system, and an equivalent round duct is calculated.
4. Select rectangular duct sizes if needed.
5. Total friction loss in the duct system is calculated for the duct run having the highest resistance.

### ***Static Regain Method***

The static regain method of duct sizing is a theoretically sound method, and meets the requirements of maintaining uniform static pressure at all branches and outlets. It is normally not applicable for return air systems where the air-

flow is towards the fan. It is more complex to use than the equal friction method. The static regain method of duct sizing may be used to design supply air systems of any velocity or pressure.

The basic principle of the static regain method is to size a duct run so that the increase in static pressure (regain due to reduction in velocity) at each branch or air terminal just offsets the friction loss in the succeeding section of duct. The static pressure will then be the same before each terminal and at each branch.

Advantages:

- Duct velocities are systematically reduced, allowing a large portion of the velocity pressure to convert to static pressure, which offsets the friction loss in the succeeding section of duct. According to the SMACNA's HVAC Systems--Duct Design manual, the static regain, which is assumed at 75 percent for the average duct system, could be as high as 90 percent under ideal conditions.
- Duct system will stay in balance because the losses and gains are proportional to a function of the velocities. Therefore, it is an excellent method for designing variable air volume systems.

Disadvantage:

- Oversized ducts can occur at the ends of long branches.

### ***T-Method***

The T-method is an optimization procedure that minimizes an objective function. This method was named after its inventor, Tsal et al. (1988). It is based on the same tee-staging idea as dynamic programming. However, phase level vector tracing is eliminated by optimizing locally at each stage. This modification reduces the number of calculations, but usually requires three iterations.

The T-method comprises the following major procedures:

1. *System Condensing.* This procedure condenses a branch Tee system into a single imaginary duct section with identical hydraulic characteristics and the same owning cost as the entire system. By using

$$K_{1-3} = [(K_1 + K_2)^{0.833}]^{1.2}$$



two children sections and a parent section may be replaced by one condensed section (ASHRAE 1989). By applying this equation from junction to junction in the direction of the root section fan, the entire supply and return systems can be condensed into one section.

2. *Fan Selection.* From the condensing system, the ideal optimum fan total pressure  $P_1(\text{opt.})$  is calculated and used to select a fan. If a fan with a different pressure is selected, its pressure ( $P\text{-opt.}$ ) is considered optimum.

3. *System Expansion.* The expansion process distributes the available fan pressure  $P(\text{opt.})$  throughout the system. Unlike the condensing procedure, the expansion procedure starts at the root section and continues in the direction of the terminals. More information on this method may be found in the 1997 ASHRAE Fundamentals Handbook. This method is one of the best ways to design ducts economically.

### ***Extended or Semi-extended Plenums***

The use of an extended or semi-extended plenum is not an entirely different method of duct or system sizing, but a combination of good design and cost saving ideas using conventional duct sizing techniques.

An extended plenum is a trunk duct of constant size, usually at the discharge of a fan, fan-coil, mixing box, constant volume box, etc., extended as a plenum to serve multiple outlets and/or branch ducts. A semi-extended plenum system is similar to extended plenum design, and incorporates a minimum number of size reductions due to decreasing volume.

### ***Velocity Reduction***

This method should only be used by experienced designers. A system velocity is selected at a section next to the fan, and arbitrary reductions in velocity are made after each branch or outlet. Balancing is attempted mainly by use of good dampers at strategic locations.

### ***Total Pressure***

A refinement of the static regain method that allows the designer to determine the actual friction and dynamic losses at each section of the duct system.

### ***Constant Velocity***

This method is better adapted to high pressure systems where attenuated terminal boxes are used to reduce the velocity and noise before distribution of air to occupied spaces.

## **Duct Fabrication and Construction**

Duct walls, transverse joints, and reinforcements at or between joints and supports make up the basic elements of duct construction. These elements form an integrated combination for each pressure class (Table A-3) and duct size. Each size in a pressure class has a minimum duct wall thickness and a minimum specification for joints, reinforcements, etc. To construct a rectangular duct with the correct thickness, joints, and reinforcing, the first step is to determine the pressure class assigned to the duct by the designer. Then the appropriate reinforcement table from SMACNA's HVAC Duct Construction Standards is used (see Figure A-27). The greater of the duct's dimension is the one that is used to determine the gage of the sheet metal for all sides. Depending on the gage selected, the table also shows whether reinforcement will be required or not. The table also indicates the right type of joint connection to use and spacing intervals for joints or reinforcements.

Round ducts have a high strength to weight ration, uses the least material to convey air at a given friction loss, and is comparatively easy to seal. SMACNA specifies the right gage to use depending on the pressure, diameter of the duct and whether a spiral or longitudinal seam is used. A 10 in. w.g. negative pressure is the maximum that is allowed for round ducts.

Flat oval ducts combine the advantages of round and rectangular ducts because they may fit in spaces where there is not enough room for round ducts, and can be joined using round duct assembly techniques. Compared to a corresponding size of rectangular duct, a flat oval duct has much less flat surface that is susceptible to vibration and requires less reinforcement. SMACNA specifies minimum duct wall thickness dependent on the duct's major dimension width and whether spiral or longitudinal seams are used. The reinforcement size and spacing interval is the same as that specified for rectangular ducts. However, flat oval ducts are for positive pressure applications only.

**READING GUIDE SUMMARY**

**Example:** 54" x 18" duct, 5 ft joint spacing. On 54" sides use F joints on 22 ga. On 18" sides flat slips or drives qualify per column 2.

**Example:** 54" x 30" duct, 22 gage. Use F at 5 ft. on 54". On 30" use D at 5 ft. or E at 10 ft. If you put joints on the 30" side at 5 ft. spacing, they must be D rated.

**Comment:** If the table requires a letter code, all joints on that side must qualify for the minimum code letter related to the minimum gage and the spacing.

Use Drive Slip or Hemmed "S" Slip on duct gage in column 2



DRIVE SLIP OR



HEMMED "S" SLIP

Duct Gage	26 to 22	20	18	16
Minimum Flat Slip and Drive Gage	24	22	20	18

Spacing refers to letter code: use joint-to-joint, joint-to-intermediate or intermediate-to-intermediate. Columns 3 to 10 are alternatives.

The drive slip is accepted as being A, B or C rated up to 20" length.

Joint Option: Backup member qualifies Hemmed "S" Slip - Reinforced or Drive Slip - Reinforced for letter code when selected from Table 1-10.

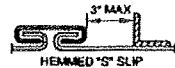

HEMMED "S" SLIP

OR



DRIVE SLIP - REINFORCED

1" W.G. STATIC POS. OR NEG. DUCT DIMENSION	TABLE 1-4 RECTANGULAR DUCT REINFORCEMENT									
	NO REINFORCEMENT REQUIRED	REINFORCEMENT CODE FOR DUCT GAGE NO.								
		10"	8"	6"	4"	3"	2 1/2"	2"	1 1/2"	1"
10" dia	26 ga.	NOT REQUIRED								
11, 12"	26 ga.	NOT REQUIRED								
13, 14"	24 ga.	B-26	B-26	B-26	B-26	B-26	A-26	A-26	A-26	
15, 16"	22 ga.	B-24	B-26	B-26	B-26	B-26	B-26	B-26	A-26	
17, 18"	22 ga.	B-24	B-26	B-26	B-26	B-26	B-26	B-26	B-26	
19, 20"	20 ga.	C-24	C-26	C-26	C-26	C-26	C-26	B-26	B-26	
21, 22"	18 ga.	C-24	C-24	C-26	C-26	C-26	C-26	B-26	B-26	
23, 24"	18 ga.	C-24	C-24	C-26	C-26	C-26	C-26	B-26	B-26	
25, 26"	18 ga.	D-22	D-24	C-26	C-26	C-26	C-26	C-26	B-26	
27, 28"	16 ga.	D-22	D-24	D-26	C-26	C-26	C-26	C-26	C-26	
29, 30"	16 ga.	E-22	D-24	D-26	D-26	C-26	C-26	C-26	E-26	
31-36"		E-20	E-22	E-24	D-26	D-26	D-26	B-26	C-26	
37-42"		F-18	F-20	E-24	E-24	E-26	E-26	D-26	C-26	
43-48"		G-16	D-18	F-20	F-22	E-24	E-26	E-26	D-26	
49-54"		H-16	H-18	G-20	F-22	F-24	E-24	E-24	E-24	
55-60"			H-18	G-20	Q-22	F-24	F-24	E-24	E-24	
61-72"				H-18G	H-18G	H-22G	F-24	F-24	F-24	
73-84"	NOT DESIGNED			I-18G	I-18G	I-20G	H-22G	H-22G	Q-22	
85-96"				I-18H	I-18H	I-20G	H-20G	H-22G	H-22G	
97-108"					I-18G	I-18G	I-18G	I-18G	I-18G	
109-120"						I-18H	I-18H	I-18G	I-18G	

See page 1-15. Circles in the Table denotes only column numbers. For column 2, see Fig. 1-7. For Columns 3 through 9, see Introduction to Schedules. The number in the box is minimum duct gage; the alphabet letter is the minimum reinforcement grade for joints and intermediates occurring at a maximum spacing interval in the column heading. A listing such as H18G means that the H may be down sized to G with a tie rod. At higher pressures and large widths, a reinforcement such as Jt means that only be rodded members are given.

TABLE 1-11 (Option) TRANSVERSE JOINT

MINIMUM RIGIDITY CLASS	T-18 STANDING B	
	H x T	WT LP
A	0.5	Use B
B	1.0	1 x 20 ga
C	1.5	1 x 22 ga
D	2.7	1 x 18 x 20 ga
E	3.5	1 1/8 x 18 ga
F	12.9	Use D
G	15.9	1 5/8 x 18 ga
H	22	
I	66	
J	80	
K	103	
L	207	

TABLE 1-10 (Option) INTERMEDIATE

REINF. CLASS	ANGLE	
	H x T (MIN)	WT LP
A	0.5	Use C
B	1.0	Use C
C	1.5	C1 x 18 ga C2M x 18
D	2.7	H24 x 18 C1 x 18
E	3.5	C1 1/4 x 18 ga H1 x 18
F	12.9	H1 1/4 x 18
G	15.9	1 1/2 x 18
H	22	1 1/2 x 3/16 2 x 1/8
I	66	C2 x 3/16 2 1/2 x 1/8
J	80	H2 x 3/16 C2 x 1/4 2 1/2 x 1/8 (+)
K	103	2 1/2 x 3/16
L	207	H2 1/2 x 1/4

OR

C angle is cold rolled.  
H angle is hot rolled.

Figure A-27. Example SMACNA Duct Reinforcement Table.

### ***Fibrous Glass Ductwork***

Fibrous glass ducts are fabricated from sheets of materials that have been manufactured from resin bonded inert and inorganic glass fibers. A factory applied facing (typically aluminum or reinforced aluminum) is applied to one face, and serves as a finish and a vapor barrier. Fibrous glass air ducts have been limited to 2 in. w.g. pressure and below.

The characteristics and requirements of fibrous glass ducts are:

- Maximum static pressure in duct - 2 in. w.g. positive or negative
- Maximum air velocity - 2000 fpm
- Maximum allowable board deflection - Transverse span/100 ft
- Maximum allowable stress in steel reinforcement - 22,000 psi
- Moisture - Moisture absorption of the board will not exceed 2 percent by weight under conditions of 120 °F DB at 95 percent RH for 96-h duration.
- Board fatigue - No significant deformation or deficiency of duct section after 25,000 cycles at 5 cycles per minute from natural sag to span/100 deflection.
- Temperature - 250 °F maximum inside the duct. 150 °F maximum ambient outside the duct.

SMACNA has a complete publication on Fibrous Glass Duct Construction Standards. It is suggested that this manual be referenced when using fibrous glass ductwork.

### ***Sealing Ducts***

To effectively close joints and seams, duct construction must have good workmanship. Ducts that are sealed as described in Table A-7 are expected to have leakage less than 5 percent of the system operating airflow. If less leakage is desired, seal all transverse joints in Class C. Refer back to Table A-3 for duct pressure classifications.

The terms "seal" or "sealed" refers to use of mastic or mastic plus tape or gasketing, as appropriate. Liquids, mastics, gaskets, and tapes have all been used as sealants. Selecting the most appropriate sealant depends on joint configuration clearances, surface conditions, temperature, the direction of pressure, and pre-assembly or post-assembly placement. Tapes should not be applied to dry metal or to dry sealant. Foil tapes are not suitable. Liquids and mastics should be used in well ventilated areas, and the precautions of manufacturers followed. Oil based caulking and glazing compounds should not be used. Gasketing should

be made of material with long life and suitable for the service. Use of thermally actuated products or products of a single source nature is not prohibited for quality sealing. The variety of sealant materials and their performance characteristics are such that a uniform specification has not yet been assembled.

<b>TABLE 1-2</b>		
<b>STANDARD DUCT SEALING REQUIREMENTS</b>		
<b>SEAL CLASS</b>	<b>Sealing Requirements</b>	<b>Applicable Static Pressure Construction Class</b>
A	Class A: All Transverse joints, longitudinal seams, and duct wall penetrations	4" w.g. and up (1000 Pa)
B	Class B: All Transverse joints and longitudinal seams only	3" w.g. (750 Pa)
C	Class C: Transverse joints only	2" w.g. (500 Pa)
In addition to the above, any variable air volume system duct of 1" (250 Pa) and 1/2" w.g. (125 Pa) construction class that is upstream of the VAV boxes shall meet Seal Class C.		

Table A-7. Seal Classes for Ductwork.

SMACNA *HVAC Systems Duct Design*, 3<sup>rd</sup> Ed., 1990. Used with permission.

### ***Provisions During Design for Testing, Adjusting, and Balancing***

Providing proper physical layouts for testing, adjusting, and balancing (TAB) the airflow in the system after the building is completed is a must. Sufficient lengths of straight duct must be provided in an accessible area to allow the TAB personnel to perform their function properly. TAB personnel must be able to determine the total system airflow with a reasonable degree of accuracy. This also applies in TAB work of the critical branches of the distribution system.

It is important for system air to get to the occupied space with minimal losses caused from leakage and resistance, with proper mixing of air, and without temperature changes from heat gains or losses. Also important are the noise, drafts, and efficiency with which air is delivered. The means to meet these requirements are the proper design of ductwork and outlets.

The designer should give special attention to the balancing and adjusting process during the design. It is necessary that the balancing capability be designed into the system initially. Below are some considerations to make when designing duct systems.

- Application of single blade, quadrant volume dampers just behind diffusers and grilles may tend to throw air to one side of the outlet, preventing uniform airflow across the outlet face or cones.
- A slight opening of an opposed blade volume damper will generate a relatively high noise level as the air passes through the damper opening under system pressure.
- To minimize generated duct noise at volume dampers, indicate damper locations at least two diameters from a fitting, and as far as possible from an outlet.
- All portions of the main return air duct system require manual balancing dampers at each duct inlet.
- Avoid placing a return air opening directly in or adjacent to the return air plenum without a noise attenuator. Lining of the duct behind the opening normally will not reduce the transmitted noise to acceptable levels.
- Mixing boxes should be located so the discharge ductwork will minimize air turbulence and stratification.
- Provide the necessary space around components of the duct system to allow a TAB technician to obtain proper readings. Allow straight duct sections of 7-1/2-in. duct diameters from fan outlets, elbows, or open duct ends for accurate traverse readings.
- Ductwork to and from air conditioning equipment should be designed carefully so stratified air may be mixed properly before entering branch ducts or equipment.
- Splitter-type dampers should be regarded as air diverters only, with maximum effectiveness when present on duct systems exhibiting low resistance to airflow.
- Manually operated, opposed blade or single blade, quadrant-type volume dampers should be installed in each branch duct takeoff after leaving the main duct to control the amount of air entering or leaving the branch.

- Turning vanes should be installed so air leaving the vanes is parallel to the downstream duct walls. Double thickness or single thickness extended edge turning vanes should be utilized in all rectangular elbows.
- Manual volume dampers should be provided in branch duct takeoffs to control the total air to the face dampers of the registers or diffusers. Use of extractors is not recommended because they can cause turbulence in the main trunk duct thereby increasing the system total pressure, and affecting the performance of other branch outlets downstream. Register or diffuser dampers cannot be used for reducing high air volumes without inducing objectionable air noise levels.
- Do not use extractors at branch or main duct takeoffs to provide volume control. Extractors are principally used to divert air to branch ducts.
- Adequate size access doors should be installed within a normal working distance of all volume dampers, fire dampers, pressure reducing valves, reheat coils, mixing boxes, blenders, constant volume regulators, etc. that require adjustments within the ductwork. Coordinate locations with the architect.
- Provide for test wells, plugged openings, etc., normally used in TAB procedures.

## 4 VAV Boxes, Diffusers, and Dampers

### VAV Boxes

A VAV box (terminal, terminal unit, throttling unit) is a device that is located where the supply duct or duct branch terminates, and the air is introduced into the space to be conditioned. Its functions include supplying air at proper temperature, regulating airflow, reducing pressure, and attenuating noise that is generated within the unit. The following are descriptions of the various types of VAV boxes.

#### ***Fan Powered VAV Box***

The fan powered VAV box (Figure A-28) induces free heat from lighting, people, and other equipment.

#### ***Single Duct VAV Terminal***

This type has only one duct connection (Figure A-29), and is supplied with air at a temperature that will take care of the cooling load. It is used only in spaces where cooling only is required year round, and where the variation in load is relatively small.

#### ***Single Duct VAV Box with Reheat***

Reheat capability is added through the use of electric coil, hot water coil, or steam. With a decrease in cooling load, the room thermostat resets the regulator to the minimum volume setting. With a further decrease in load, the thermostat opens the reheat valve.

#### ***Dual Duct VAV Terminal***

The dual duct VAV terminal (Figure A-30) is supplied with both hot and cold air. The inlet valve is positioned by a pneumatic motor or electric motor in response to a room thermostat to supply air at the proper temperature to satisfy the load



within the space. With a decrease in cooling load, the room thermostat resets the regulator to the minimum volume setting. With a further decrease in load, the thermostat gradually opens the warm air damper.

### ***Bypass VAV Terminal***

This type of VAV box (Figure A-31) has a constant cfm input. Unneeded air is bypassed directly into the ceiling plenum. Bypassing of the excess air out of the system and into the plenum will maintain the proper airflow into the occupied space and help ensure the comfort of the occupants.

### ***Retrofit Terminals***

Existing constant volume systems can be converted to VAV systems for the purpose of conserving energy (Figure A-32). Low velocity constant volume reheat, high velocity constant volume reheat systems, and the double duct constant volume system can be converted by using an appropriate retrofit terminal.

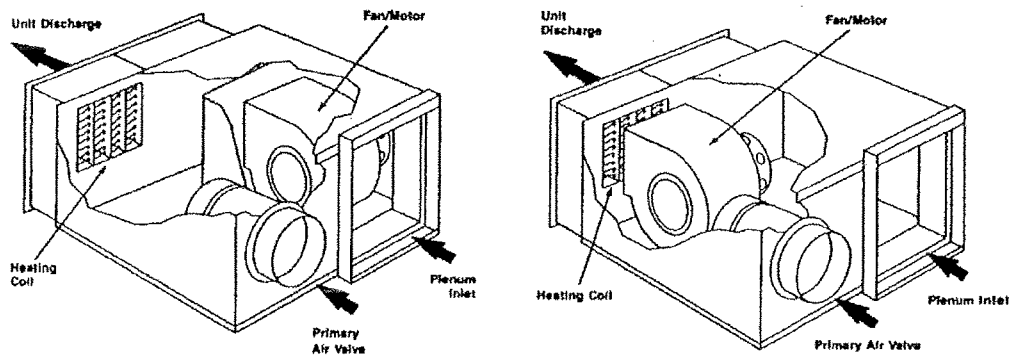

**Figure A-28. Fan Powered VAV Box.**

Provided by Titus.

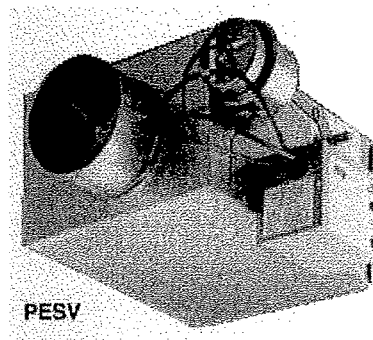

**Figure A-29. Model ESV Single Duct VAV Terminal.**

Provided by Titus.

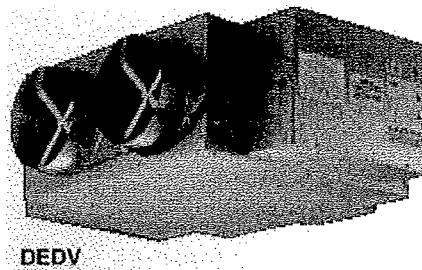

**Figure A-30. Model MDV/MDC Dual Duct Terminal.**

Provided by Titus.

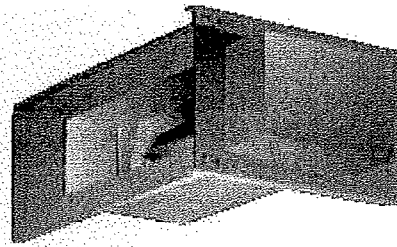

**Figure A-31. Titus Model ZQCV Bypass Terminal.**

Provided by Titus.

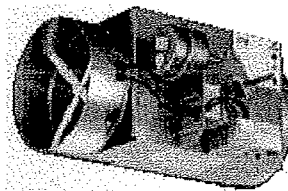
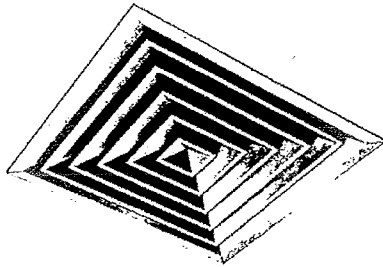

**Figure A-32. VAV Retrofit Terminal.**

Provided by Titus.

## Diffusers

Air diffusers discharge supply air. Diffusers come in many different shapes and sizes and are usually located in the ceiling. Deflecting members in the diffuser discharge the supply air in various directions to promote mixing of primary air with secondary room air. Diffusers can be selected based on general configuration, sound level, supply or return, throw, airflow rate, balancing devices, and pressure drop. Figure A-33 shows a few of the various diffuser shapes available.



(a) Model TDC Square & Rectangular Ceiling Diffuser.

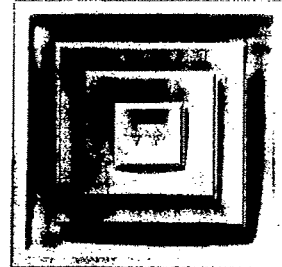

(b) Model TDC-NT Narrow Tee-Louvered Face Diffuser.

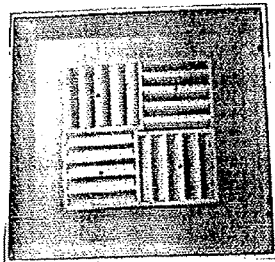

(c) Model PMC Perforated Ceiling Diffuser.

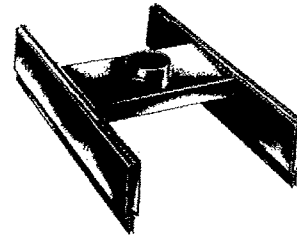

(d) Model LTT Fluorescent Light Troffer Diffuser.

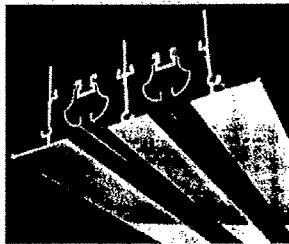

(e) ML Series Linear Slot Aluminum Modulinear Diffuser.



(f) Model 301RL 300/350 Supply Grilles and Registers.



(g) Model TMRA Round Ceiling Diffuser.

Figure A-33. Diffuser Types.

Provided by Titus.

When the sound level is critical in selecting a diffuser, be aware that the noise generated by the diffuser will be substantially higher than the manufacturer's published data when a duct turn precedes the entrance to the diffuser or if a balancing damper is installed immediately before the diffuser.

The throw of a diffuser is the horizontal and vertical axial distances that the air-stream travels at various velocities after leaving the diffuser. The throw values listed in a manufacturer's table are based on specified velocities. The room section in Figure A-34 illustrates the throw pattern of air leaving a ceiling diffuser. In this example, the selected diffuser with an airflow of 200 cfm has throw values of 15-19-27 based on terminal velocities of 150, 100, and 50 fpm, respectively. Several techniques are available for applying throw data. A few of these are illustrated in Figure A-35.

Figure A-36 is a typical manufacturer's chart, and illustrates the selection process for the diffuser shown in Figure A-33(e). In the example, the area under consideration requires (by design) 85 cfm per ft. The diffuser selected is a 4 slot linear diffuser with 100 cfm per foot, and throw values of 15-19-27. Using the room configuration from Figure A-35, and designing for heating and cooling, the throw values required are 7-11-19.

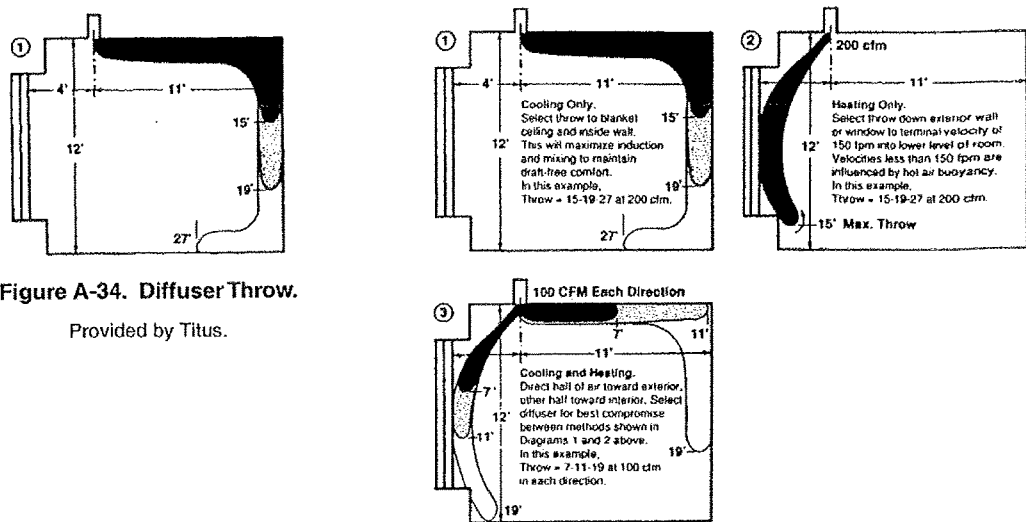

### Supply Performance Data for Plenum Applications

- All pressures are in inches of water.
- Throw values are based on an active section 3 feet long. For a 1 foot section the throw values are 0.6 times those shown. For a 10 foot or longer continuous length, the throw values are 1.8 times those shown.
- Horizontal (H) throw values are given for terminal velocities of 150, 100 and 50 fpm.
- Horizontal (H) throw values are based on air discharged in the same direction from all slots.
- For divided throw, use the cfm-per-foot value for the number of slots in each direction. For sound, use the NC values for cfm-per-foot for the total number of slots.
- Vertical (V) throw values are given for a terminal velocity of 50 fpm.
- NC values are based on a room absorption of 10 dB, re 10<sup>-12</sup> watts, with a 10 foot active diffuser section (see the table of corrections below) and with horizontal throw. For vertical throw, deduct 11 dB from each NC value.
- For continuous lengths, the selection for NC is usually based on a 10 foot section.
- Dash (—) in space denotes NC value less than 10.
- Data were obtained from tests conducted in accordance with ISO Standard 5219, ISO Standard 3741 and ADC Test Code 1062 GRD84.

#### Model ML-37

No. of Slots	Total Press.	H V	005 003	019 012	043 029	075 050	117 080	170 114	225 155	290 200
1	CFM per Ft.		5	18	15	20	25	30	38	48
	Throw, Feet	H V	1-1-2 2	1-2-9 6	2-5-11 9	4-9-13 11	7-10-14 12	9-18-15 14	9-11-16 15	10-12-18 16
	NC		—	—	—	17	23	29	33	38
2	CFM per Ft.		18	29	38	48	58	68	78	88
	Throw, Feet	H V	1-1-4 4	2-4-12 8	5-9-15 13	8-12-17 16	10-14-19 17	12-15-21 19	13-16-23 20	14-17-24 22
	NC		—	—	13	22	28	34	38	43
3	CFM per Ft.		18	30	45	60	75	90	105	120
	Throw, Feet	H V	1-2-7 5	3-7-15 10	7-11-18 15	10-15-21 19	13-16-23 21	15-18-25 23	16-19-27 25	17-21-29 27
	NC		—	—	16	25	31	37	41	46
4	CFM per Ft.		20	40	60	80	100	120	140	160
	Throw, Feet	H V	1-2-9 7	4-9-17 12	9-13-21 18	12-17-24 22	15-19-27 25	17-21-29 27	19-23-32 29	20-24-34 31
	NC		—	—	18	27	33	39	43	48
5	CFM per Ft.		25	50	75	100	125	150	175	200
	Throw, Feet	H V	1-3-10 7	6-10-19 14	10-15-23 20	13-19-27 25	17-22-30 28	20-24-33 30	21-25-35 32	23-27-38 35
	NC		—	—	19	28	34	40	44	49
6	CFM per Ft.		30	60	90	120	150	180	210	240
	Throw, Feet	H V	2-4-11 7	7-11-21 16	11-18-26 22	15-21-29 27	18-24-33 30	21-28-36 33	23-28-39 35	24-30-42 38
	NC		—	—	20	29	35	41	45	50
7	CFM per Ft.		35	70	105	140	175	210	245	280
	Throw, Feet	H V	3-6-16 8	8-11-23 16	12-18-28 24	16-23-32 29	20-28-36 32	23-28-39 35	25-30-42 38	26-32-45 41
	NC		—	—	21	30	36	42	46	51
8	CFM per Ft.		40	80	120	160	200	240	280	320
	Throw, Feet	H V	3-6-13 8	8-12-24 17	13-19-29 26	17-25-34 31	22-27-38 35	24-30-42 38	26-32-45 41	28-36-48 43
	NC		—	10	22	31	37	43	47	52

#### NC Correction for Various Diffuser Lengths

Length, Feet	1	2	4	6	8	10	15	20	25	30
Supply	-15	-11	-6	-3	-2	0	+3	+5	+6	+8
Return	-10	-7	-4	-2	-1	0	+2	+3	+4	+5

Figure A-36. Supply Performance Data for Plenum Applications.

Provided by Titus.

Slot diffusers are often used for VAV systems. This type of diffuser distributes the air in a uniform pattern. The direction and volume of the discharge air can be adjusted.

Properly selected VAV diffusers, due to their design, will maintain proper air circulation at varying discharge flow with minimum effect on horizontal throw, and with minimum air dumping.

## Dampers

A damper is a device used to vary the volume of air passing through an air outlet, air inlet, or duct. Tight-closing dampers provide energy savings by eliminating leakage of hot or cold air. Several manufacturers have designed dampers that are capable of shutting off a very high percent of air leakage. Some have accomplished this by having rubber seals on the ends of the damper blades, which, when fully closed, interlock and allow little air to pass between the blades. Air leakage may occur, however, around the outside of the blades between the frame and blades. Several types of dampers are available for HVAC systems. A few of them will be discussed in brief.

*Motorized Control Dampers:* Dampers that open or close to divert, direct, or shut off airflow in the primary duct system. Blades should have sealing edges using felt, rubber, etc. to ensure a tight cutoff of the airstream when closed.

*Back-Draft Dampers:* Back-draft dampers close under the action of gravitational force when no air is flowing and open when there is a drop in pressure across the damper in the direction of desired air flow. This prevents an undesirable backward flow of air or back-draft.

*Multi-Shutter Damper:* The parallel blade damper will deflect airstream when the damper is partially open. It is used to adjust air volume only when airstream deflection is acceptable.

*Multi-Louver Round Diffuser Damper:* This damper is a series of parallel blades and adjusts the air volume to the space.

*Opposed Blade Round Diffuser Dampers:* A series of pie-shaped blades are mounted in a round frame to adjust the air volume.

*Diffuser Splitter Damper:* This damper is a single plate hinged at the duct branch connection to the outlet and is used only with an equalizing device to adjust volume to the space.

Figure A-37 illustrates various types of dampers.

Volume control dampers come in "opposed" blades or "parallel" blades. When it is partially closed, the parallel blade damper diverts the air stream to the side of the duct (Figure A-37, bottom left). This will cause a non-uniform velocity profile

beyond the damper, and flow to close branch ducts on the downstream side may be seriously affected. Use of an opposed blade damper is recommended when volume control is required at the fan outlet, and there are other system components such as coils or branch takeoffs downstream of the fan. When the fan discharges into a large plenum or to a free space, a parallel blade damper may be satisfactory.

One important final point in considering dampers, obstructions in the duct work, and other components of the HVAC system (for purposes of calculating pressure drops, etc.) is to remember the placement of required fire dampers.

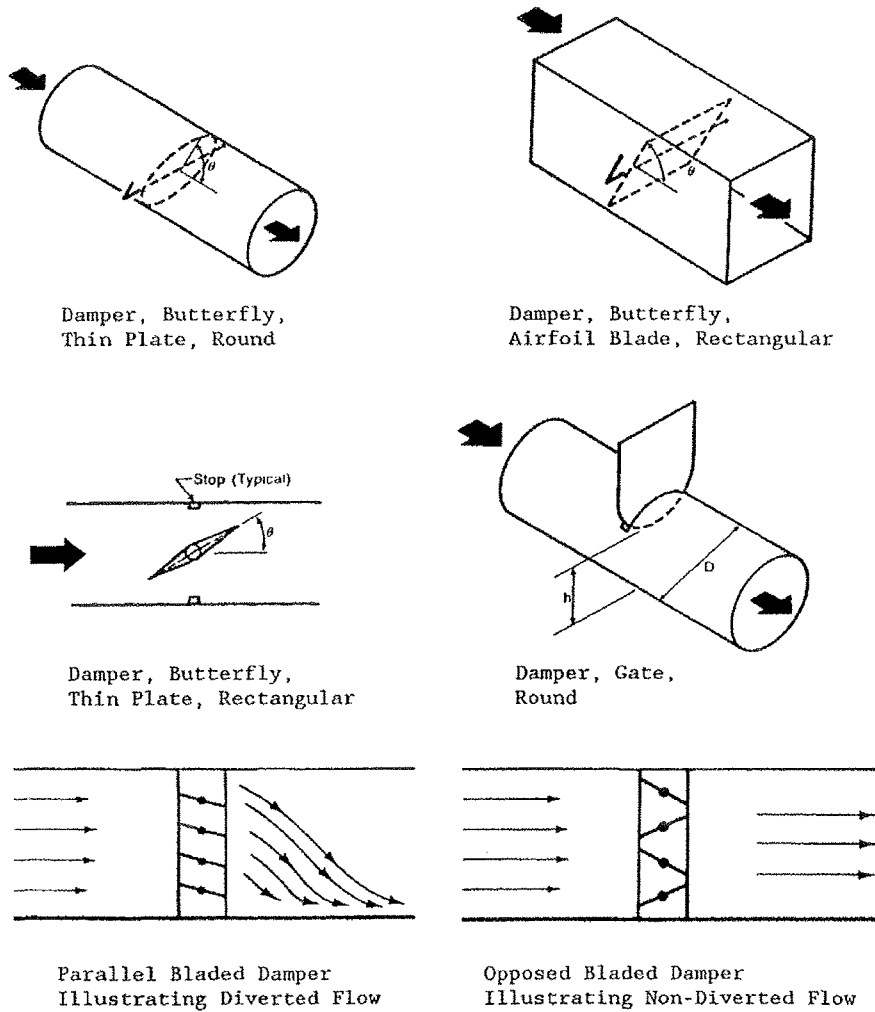

Figure A-37. Damper Types.

SMACNA, *HVAC Systems Duct Design*, 3<sup>rd</sup> Ed., 1990. Used with permission.

## 5 VAV Controls

A heating, ventilating, and air-conditioning (HVAC) system, its control system, and the building in which they are installed should be viewed as inseparable parts of a single entity. They interact in many ways, and neglecting any element may cause a partial or complete loss of controllability. It is important to consider that no HVAC system is better than its controls and the building in which it is installed.

In general, only three basic elements are necessary for a control system: sensor, controller, and controlled device. A sensor measures the temperature of the air and passes the information on to the controller. The controller compares the air temperature to a set point, then sends a signal to open or close the controlled device as required to maintain correspondence between the air temperature and the set point.

The HVAC system operates most economically when equipment capacity is closely matched to load. This may be accomplished better with an automatic control system than manually. A completely automatic system with changeover controls, interlocks, and internal monitoring and compensating controls minimizes human intervention and the chance of human error.

Control systems must have some source of energy to make them work. There are six sources generally used to cause control actions:

*Electric Systems:* Electric systems provide control by starting and stopping the flow of electricity, or varying the voltage and current by means of rheostat or bridge circuits.

*Electronic Systems:* These systems use very low voltages (24 V or less) and currents for sensing and transmission, with amplification by electronic circuits or servo-mechanisms as required for operation of controlled devices.



*Pneumatic Systems:* Pneumatic systems usually use low-pressure compressed air. Changes in output pressure from the controller will cause a corresponding position change at the controlled device.

*Hydraulic Systems:* These are similar in principle to pneumatic systems but use a liquid or gas rather than air. These systems are usually closed, while pneumatic systems are open (some air is wasted).

*Fluidic Systems:* Fluidic systems use air or gas and are similar in operating principles to electronic as well as pneumatic systems.

*Self-Contained System:* This type of system incorporates sensor, controller and controlled device in a single package. No external power or other connection is required. Energy needed to adjust the controlled device is provided by the reaction of the sensor with the controlled variable.

In actuality, what is controlled is the environment of enclosed spaces. As the environment's temperature, humidity, and pressure levels fluctuate, they become the "controlled variable." Control actions depend first on measurement of the controlled variable. Accurate and rapid measurement is the most serious problem in the control industry. It is difficult to get an accurate instantaneous reading, especially if the controlled variable is fluctuating or changing very rapidly.

The materials of which the sensors are made, their placement in the system, and the source of energy used for response may slow down the process that is so critical for accuracy. For example, thermostats will be affected by the presence or absence of air motion, temperature of the surface on which they are mounted, radiant heat from windows, etc. A pressure sensor placed at a point of turbulence (turn point or change in pipe size) in fluid cannot provide accurate or consistent readings.

Delay due to the distance over which the signal is transmitted is another problem that will arise in measurement or control. Pneumatic signals will travel only at sonic speeds and are subject to fluid friction losses. Electric signals may become seriously attenuated by resistance in long lines. These are only a few of the obvious problems encountered when designing a control system. Someone with a deeper knowledge and background in thermodynamics and electrical theory will more readily identify the problem areas in the design process.

The function of a military building may change several times in its existence and eventually will come the complaints of a bad thermal system design. Typically, when the environment is not properly controlled, the blame is placed on the control system, but in many cases, it is due to the HVAC system or building itself. The building must be designed to allow the degree of environmental control required. A warehouse cannot be used as a clean room, yet similar extremes have been experienced. This brings out the fact that a sophisticated control system will not compensate for the errors of a poorly designed HVAC system and will cost more in the future to maintain.

The following sections will discuss in greater detail the operation of thermostats, system control, and direct digital control.

## **Thermostats**

Many instruments can be used for measuring temperature. Table A-8 lists some of these with a brief explanation of each.

### ***Explanation of Thermostat Operation***

In Figure A-38, a flapper-nozzle operation is shown. The thermostat provides a branch line airflow (pressure) that is a function of the ambient temperature in the room or controlled space. The force of the temperature sensing bimetal acting on the flapper is balanced by the feedback force of the pilot pressure acting on the opposite side of the flapper through the nozzle. When this force changes due to temperature or set point change, the position of the flapper changes over the nozzle and a new pilot chamber pressure is created. This pilot pressure feeds into the valve unit flow amplifier, which converts the low capacity pilot pressure to a higher capacity branch line change.

Table 1 Temperature Measurement

Measurement Means	Application	Approximate Range, °F	Uncertainty, °F	Limitations
<b>Liquid-in-glass thermometers</b>				
Mercury-in-glass	Temperature of gases and liquids by contact	-36/1000	0.05 to 3.6	In gases, accuracy affected by radiation
Organic	Temperature of gases and liquids by contact	-330/400	0.05 to 3.6	In gases, accuracy affected by radiation
Gas thermometer	Primary standard	-456/1200	Less than 0.02	Requires considerable skill to use
<b>Resistance thermometers</b>				
Platinum	Precision; remote readings; temperature of fluids or solids by contact	-430/1800	Less than 0.0002 to 0.2	High cost; accuracy affected by radiation in gases
Rhodium-iron	Transfer standard for cryogenic applications	-460/-400	0.0002 to 0.2	High cost
Nickel	Remote readings; temperature by contact	-420/400	0.02 to 2	Accuracy affected by radiation in gases
Germanium	Remote readings; temperature by contact	-460/-400	0.0002 to 0.2	
Thermistors	Remote readings; temperature by contact	Up to 400	0.0002 to 0.2	
<b>Thermocouples</b>				
Pt-Rh/Pt (type S)	Standard for thermocouples on IPTS-68, not on ITS-90	32/2650	0.2 to 5	High cost
Au/Pt	Highly accurate reference thermometer for laboratory applications	-60/1800	0.1 to 2	High cost
Types K and N	General testing of high temperature; remote rapid readings by direct contact	Up to 2300	0.2 to 18	Less accurate than listed above thermocouples
Iron/Constantan (type J)	Same as above	Up to 1400	0.2 to 10	Subject to oxidation
Copper/Constantan (type T)	Same as above, especially suited for low temperature	Up to 660	0.2 to 5	
Ni-Cr/Constantan (type E)	Same as above, especially suited for low temperature	Up to 1650	0.2 to 13	
Beckman thermometers (metastatic)	For differential temperature in same applications as in glass-stem thermometer	10°F scale, used 32 to 212°F	0.01	Must be set for temperature to be measured
Bimetallic thermometers	For approximate temperature	-4/1200	2, usually much more	Time lag; unsuitable for remote use
<b>Pressure-bulb thermometers</b>				
Gas-filled bulb	Remote testing	-100/1200	4	Caution must be exercised so that installation is correct
Vapor-filled bulb	Remote testing	-25/500	4	Caution must be exercised so that installation is correct
Liquid-filled bulb	Remote testing	-60/2100	4	Caution must be exercised so that installation is correct
Optical pyrometers	For intensity of narrow spectral band of high-temperature radiation (remote)	1500 and up	30	
Radiation pyrometers	For intensity of total high-temperature radiation (remote)	Any range		
Seeger cones (fusion pyrometers)	Approximate temperature (within temperature source)	1200/3600	90	
Triple points, freezing/melting points, and boiling points of materials	Standards	All except extremely high temperatures	Extremely precise	For laboratory use only

Table A-8. Temperature Measurement Instruments.

Reprinted with permission from the 1997 ASHRAE Handbook.

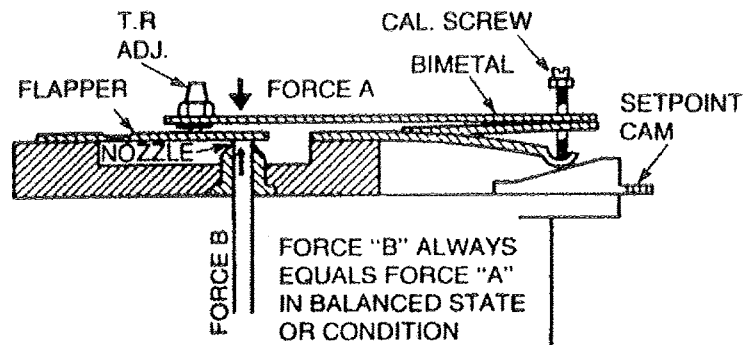

Figure A-38. Flapper-nozzle Operation.

Reproduced with the permission of the National Environmental Balancing Bureau, December 1996.

In this thermostat, a feedback feature at the nozzle provides a pressure regulating effect that negates the effect of normal air supply functions on the branch line.

### Applications

Thermostats serve several purposes other than the single, simple-purpose type:

- The *day, night, or dual room* thermostat controls at a reduced temperature at night. Some electric types have an individual clock and switch built into the thermostat. A pneumatic "day-night" thermostat uses a two-pressure air supply system.\* Changing the pressure at a central point from one value to the other actuates switching devices in the thermostat and indexes them from day to night or vice versa.
- *Heating-cooling, summer-winter* thermostats may have their action reversed, and if desired, may have their set point changed by the indexing means. Pneumatic "heating-cooling" thermostats use a two-pressure air supply.
- The *multi-stage* thermostat is arranged to operate two or more successive steps in sequence.

\* Air pressure is varied through the same tube for summer and winter.

- A *submaster* thermostat has its set point raised or lowered over a predetermined range, in accordance with variations in output from a master controller.
- *Wet bulb* thermostats are used for humidity control with proper control of the dry bulb temperature. A wick or other means for keeping the bulb wet and rapid air motion to assure a true wet bulb measurement are essential.
- A *dewpoint* thermostat is a device designed to control from dewpoint temperatures.
- A *variable volume temperature system monitor* thermostat (made by Carrier only) communicates with as many as 36 other zone thermostats and has a digital display for set points. This thermostat uses the equation  $q_s = 1.08 \times \text{time} \times \text{cfm} \times \Delta T$ .
- *Discriminating* thermostats are electronic two-stage cooling, two-stage heating control devices. The discriminating thermostat uses solid state devices to turn on its stages and should be able to operate any air conditioning system that does not require special switching.

The location of these space controllers must represent the conditions of the whole zone served by the controller. In large open areas that have more than one zone, thermostats should be in the middle of their zone to assure they are not affected by conditions in the surrounding zones. Three different locations for space temperature controllers are in common use:

- *Wall-mounted thermostats* are usually placed on inside walls or columns in the occupied space they serve. Outside wall locations should be avoided. Thermostats should not be mounted where they will be affected by heat from other sources such as direct rays of the sun, pipes or ducts in the wall, convectors, direct air currents from diffusers, etc. The location should provide ample air circulation unimpeded by furniture or other obstructions, and should afford protection from mechanical injury. They should never be placed in spaces such as corridors, lobbies, foyers, etc., unless used only for control of these areas.
- *Return air thermostats* can be used for control of floor-mounted unitary conditioners such as induction fan-coil units and unit ventilators. On induction and fan-coil units, the sensing element will be located behind the return air

grille. On classroom unit ventilators that use up to 100 percent outdoor air for natural cooling, however, a forced flow sampling chamber will normally be provided for the sensing element. If return air sensing is to be used with central fan systems, the sensing element should be located as near the space being controlled as possible to eliminate influence from other spaces, and the effect of any heat gain or loss in the duct. Where combination supply/return air light fixtures are used to return air to a ceiling plenum, the return air opening of a light fixture can be used as a location for a return air sensing element. Precaution should be taken in location of the sensing element to avoid radiant effect, assure adequate air velocity across the element, and provide means for future access for servicing.

- *Diffuser-mounted thermostats* usually have sensing elements mounted on ceiling supply diffusers of the circular or square type and depend on aspiration of room air into the supply airstream. They should be used only on high aspiration diffusers that are adjusted for a horizontal air pattern. The diffuser in which the element is mounted should be in the center of the occupied area of the zone being controlled.

## VAV System Control

Control system components, when combined to control an HVAC system, are defined as control loops. These control loops are further defined into two types, the open loop and closed loop.

An open loop control system usually takes corrective action to offset effects of external disturbance on the variable of interest in the system. The action is sometimes called the feed-forward control because it is anticipating the effect of an external variable on the system. This type of control does not provide complete control from the space temperature viewpoint.

The closed loop control system has a controller that measures the actual changes in the controlled variable, and actuates the controlled device to bring about an opposite change, which is again measured by the controller. The corrective action is a continuous process until the variable is brought to a desired value within the design limitations of the controller. This system of transmitting information about the results of an action or operation back to its origin is known as feedback and makes true automatic control possible.

A subsystem is any system that is part of a larger system. An HVAC system may have several subsystems (i.e., a system to control pressure, one to control temperature, dampers, supply fan, etc). Each of these is part of the whole system. Having discussed the various components of a control loop and their function and explained what a control loop is, an example of controlling a VAV system will now be discussed. Figure A-39 shows the control diagram for a VAV system with an economy cycle and discriminator reset. This is perhaps as elaborate as is practical using conventional control hardware.

The control system has five essentially separate control subsystems, although they all interact. The first, on the right of Figure A-39, is the loop controlling the zone damper. Figure A-40 shows an expanded view of this control subsystem and shows a reheat coil that might be needed in exterior building zones. The "inner" or most direct loop here consists of the flow sensor, which modulates the zone damper to control the flow to the zone under varying duct pressures. Another "outer" loop consists of the room thermostat, which changes the set point of the flow control loop to vary the temperature. When reheat is required, the room thermostat has direct control over the reheat valve.

The next subsystem, to the left of the zone damper loop, is controlling the supply fan air volume. This is perhaps the simplest loop in the system. The differential pressure sensor, SP, transmits a signal to the receiver/controller RC3 which compares it to the receiver/controller set point. The output from RC3 controls whatever type of fan pressure control system is used (e.g. variable speed drive, inlet vanes or discharge dampers).

The next loop to the left is the loop that modulates the heating and cooling coil in sequence to control the fan discharge air temperature (T3 through RC2 to valves V1 and V2). Note that this "inner" loop has its set point changed by an outer loop consisting of the room thermostat in the hottest zone, which is adjusting the set point of the supply air temperature loop to control room temperature. Also note that valves V1 and V2 should operate in sequence to avoid wasteful simultaneous heating and cooling.

The economy cycle loop is essentially the same as the heating and cooling coil loop and also has a "reset" signal from the hottest zone. However, the two-position action of T1 acts through R1 to switch the damper position control loop in and out of service depending on outdoor air temperature.

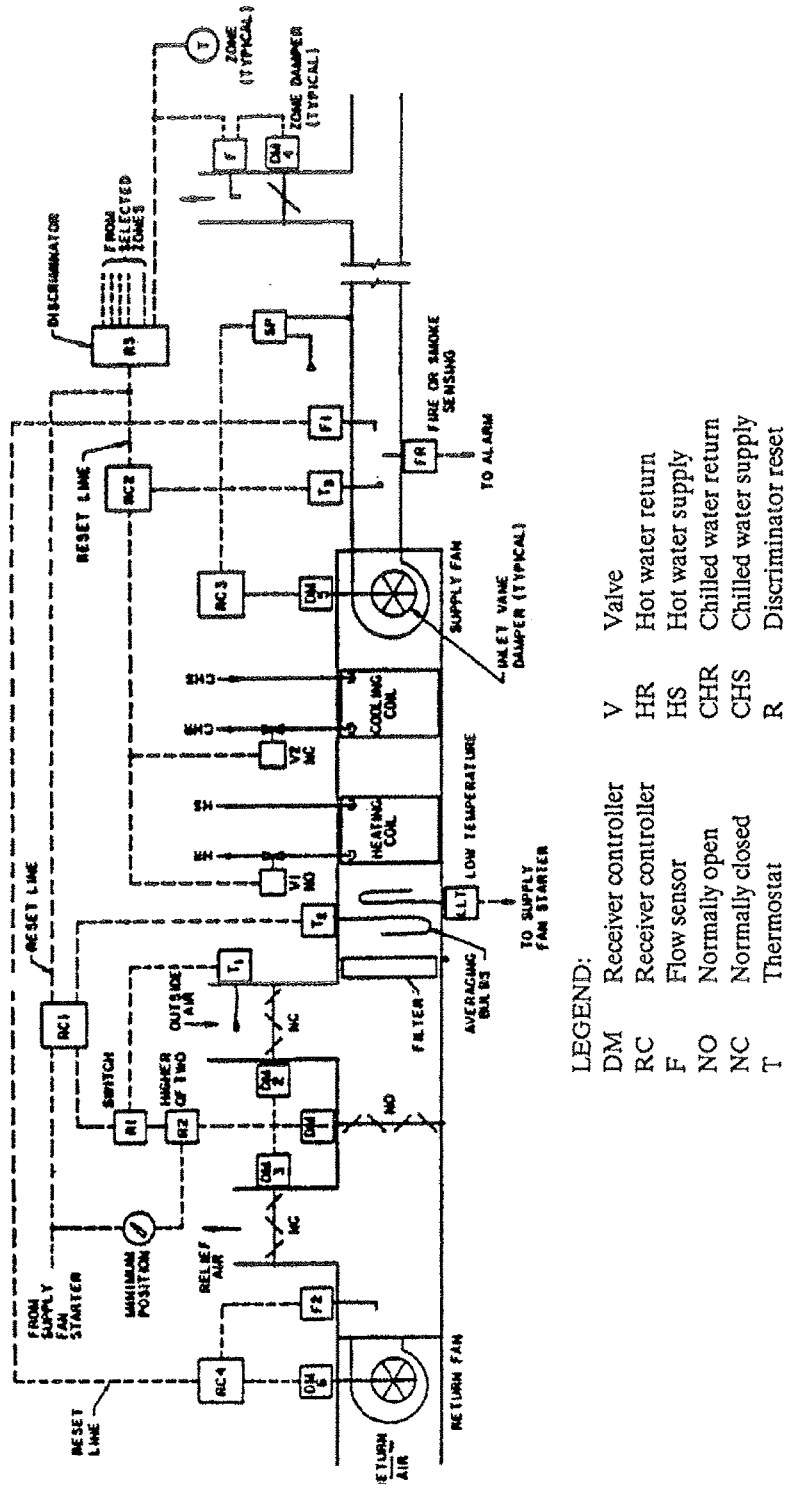

Figure A-39. Example VAV System Control Diagram.  
 Reprinted with permission from Automatic Temperature Control for Energy / Cost Effectiveness, ASHRAE Energy Professional Development Series.



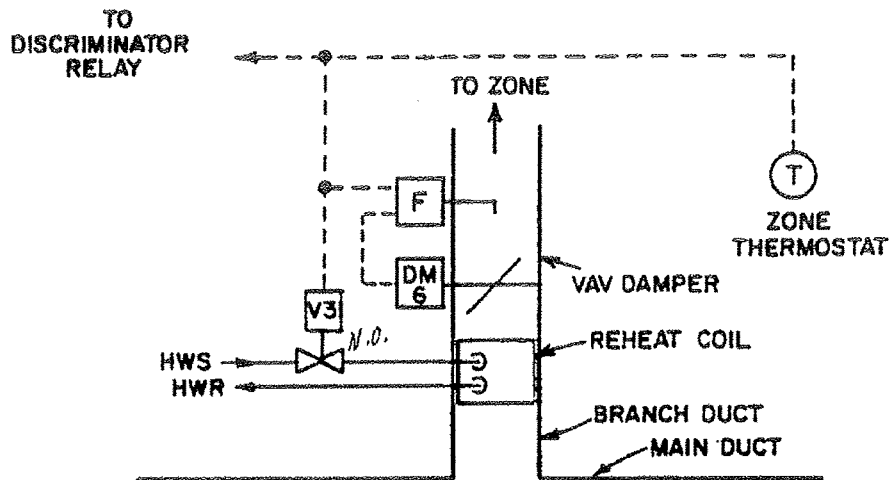

Figure A-40. Zone Damper Control Loop.

Reprinted with permission from *Automatic Temperature Control for Energy / Cost Effectiveness*, ASHRAE Energy Professional Development Series.

There is a return fan control loop where the signal from flow sensor F2 is compared with the "set point" in RC4, and the output of RC4 modulates the return fan. The "set point" is a reset signal from F1.

The last return fan control system is an example of some of the less-than-precise terminology (some of which is in quotes above) used in describing HVAC control systems. In this case, when the fan speed or damper position changes, flow sensor F1 reads essentially the same change in flow as F2, and it responds just as quickly. Neither sensor signal is really a "reset" signal in this case. Both represent equally important and similar feedback paths, and both feedback signals occur without delay.

### Direct Digital Control (DDC)

The following overview is given to familiarize the reader with DDC systems so that they will not be intimidated by DDC if they encounter it in the field. If DDC is used, this information will also help provide an understanding of its applications and operations.

An analog computer is defined as a computer that operates with numbers represented by directly measurable quantities. Analog control systems are standard

today and are basically understood by most specifiers, installers, users, and maintenance personnel. The idea of changing to a new, digital system could be of great concern and an area of resistance for many personnel.

Many factors should be considered in selecting a DDC system: price, feature, service availability, track record of distributor, track record of manufacturer, and history of dependability. To avoid pitfalls, beware of unknowledgeable manufacturers, designers, specifiers, suppliers, installers, operators, and maintenance personnel. To prioritize these factors, one must determine the criticality of the process to which the DDC system is to be applied. In addition to the preceding considerations, one must beware of a system manufactured without assurance of direct replacement compatibility. Many products, especially electronic or computer products, can become obsolete before the normal building project can be completed. They are purposely designed to be discarded rather than repaired upon failure.

DDC is considered to be the automatic control or condition of a process by a digital computer. The size of the computer varies from a very small microprocessor to a central microcomputer. The controlled device (damper operator, valve operator, stepping relays, etc.) may be pneumatic, electric modulating, or two position. (It is often said that the system will be either pneumatic or DDC. This means that the system may be DDC and pneumatic, with the DDC system replacing the pneumatic controller but operating the same pneumatic-controlled device.)

The DDC system uses a combination of computer hardware components and software (computer disks, etc.) to maintain the controlled variable (temperature, pressure, relative humidity, flow rate, level, etc.) according to the desires of the operator. Instead of calibrating the hardware controller, the control sequence and set point are input to the computer by software and modified by a keyboard entry at the operator's console.

The DDC system monitors the controlled variable (temperature, pressure, etc.) and compares the value stored in the computer. When the measured value is not equal to the desired value, some systems output a series of digital pulses that are converted to the controlled device by an electric-to-pneumatic transducer. Transducers maintain the output signal until readjusted by the computer. Other systems may change the control signal by a series of flip flops (on-off or open-close signals) to bleed air into or out of a pilot relay or the control line. Some interfacing signal device will always be required to isolate the computer output circuitry from the control signal circuitry.

Keyboard functions and the printouts should be clearly defined, and the printouts and indications should be easily interpreted so the operator will be quickly advised of an incorrectly inserted command. Just because a system is labeled user friendly does not mean it will be at the level any operator can interpret. Therefore, prospective buyers should investigate before purchasing.

Some of the advantages of using a DDC system are listed below:

- *Energy Optimization:* A deadband or zero energy band can be programmed into the system, thereby reducing the energy consumption for heating and cooling. This requires no additional hardware because the system already requires control interconnection to the heating and cooling controlled devices. Other energy saving routines are:
  - Close outside air damper when outside air temperature exceeds a predetermined point
  - Close outside air damper during building warm-up, prior to occupancy time
  - Open outside air damper for pre-occupancy cool down
  - Close cooling and heating water valves prior to system shut down at the end of the day
  - Conservation of central plant energy by use of proper control strategies to optimize operation of chillers, boilers, heat exchangers, etc.
  - Precise control of controlled variable when desired
  - Heuristic control is available on most well-designed DDC systems. This feature is useable for warm up or cool down (optimum start).
- *Competitively Priced:* For today's computer products, the trend has been that prices go down.
- *Multi-Schedule Capabilities:* During a single day, there could be several set points (temperatures) for the building. Also, the system may be programmed to cycle the equipment off during lunch time.

- *Remotely Accessible:* With the aid of a telephone modem, many DDC systems may be accessed for readouts and adjustments from any remote location that has a telephone by the use of a computer input terminal keyboard or a separate properly programmed computer. This permits a single operator to monitor many systems and buildings from a single location.
- *Unauthorized Tampering Prevented.*

In the end, the final user holds the ultimate key to the successful operation of the total DDC system. If a perfect system is designed, a perfect product is chosen, a perfect installation is performed, and a perfect control strategy is programmed and commissioned, but the user does not care to understand or maintain the system in its perfect state, the whole system will fail. User education must start early to ensure satisfaction for all parties to the project.

## 6 Acoustical Considerations

In considering the acoustical performance of an HVAC system, it is important to develop a vocabulary of acoustical terminology. The following definitions will aid in understanding the proceeding overview of acoustical considerations for VAV systems.

- *Aerodynamic Noise:* Also called generated or self-generated noise, is noise of aerodynamic origin in a moving fluid arising from flow instabilities. In duct systems, aerodynamic noise is caused by airflow through elbows, dampers, branch wyes, pressure reduction devices, silencers, etc.
- *Airborne Noise:* Noise that gets to observer by transmission through air.
- *Background Noise:* The irreducible noise level measured in the absence of any building occupants.
- *Breakout Noise:* The transmission or radiation of noise from a part of the duct system to an occupied space in the building. Also referred to as "flanking" and "duct radiation."
- *Noise:* Sound which is unpleasant or unwanted by the recipient.
- *Room Effect:* The difference between the sound power level discharged by a duct (through a diffuser or other termination device) and the pressure level heard by an occupant of a room.
- *Sound Power Level ( $L_W$  or  $PWL$ ):* The fundamental characteristic of an acoustic source (fan, etc.) is its ability to radiate power. Sound power level cannot be measured directly; it must be calculated from sound pressure level measurements. Sound pressure level is comparable to the measurement of temperature in a room, whereas the sound power level is comparable to the cooling capacity of the equipment conditioning the room. The resulting temperature is a function of the cooling capacity of the equipment, and the heat gains and losses of the room. In the same way, the resulting sound pressure

level would be a function of the sound power output of the equipment together with the sound reflective and sound absorptive properties of the room.

- *Structure Borne Noise:* This condition is apparent when sound waves are being carried by a portion of the building structure. This noise is translated from radiation of structure borne sound into the air.

Many sources of noise are found in VAV systems. Noises transmitted through the duct system are from fan, aerodynamics, and duct termination devices. Fan manufacturers usually provide sound power level data in octave bands. If this information is unavailable, accurate data may be calculated if volume flow rate, static pressure, and type of fan are known by use of equations and charts. These equations and charts are located in literature such as *ASHRAE Fundamentals* handbooks and SMACNA's *HVAC Systems Duct Design*.

Aerodynamic noise is generated when airflow in a duct system becomes turbulent as it passes through sharp bends, sudden enlargements or contractions, and other devices that cause a substantial pressure drop. Aerodynamic noise is important to consider at velocities above 2000 fpm in the main ducts, 1500 fpm in branch ducts, and 800 fpm in ducts serving room terminal devices. When duct system velocities are as listed above or when the duct does not follow good airflow design principles, aerodynamic noise may become a major problem. Aerodynamic noise is usually from 31.5 through 500 Hz octave band center frequencies, which are low frequencies. Because of the magnitude of low-frequency energy, it transmits readily with not much loss through light gauge walls of ducts, and through suspended acoustical ceilings.

With regard to duct terminal devices, pressure reducing valves in mixing and variable volume boxes usually have published noise ratings indicating the sound power levels that are discharged from the low pressure end of the box. Manufacturers may specify the requirements, if any, for sound attenuation materials between the outlet and box in the low pressure duct. If boxes are located away from critical areas such as mechanical rooms, janitorial closets, or corridors, the noise radiating from the box may be of no concern. If the box is located above a critical space, and separated from the space by a suspended acoustical ceiling that has little or no transmission loss at low frequencies, the radiated noise from the box may exceed the noise criterion for the room below. In such a case, relocate the box or encase it with a construction having a high transmission loss.

Room air devices such as diffusers, grills, light fixtures, and air handling ceiling suspension bars are always rated for noise generation. The room air terminal unit is selected to meet the noise criterion (N.C.) required or specified for the room, bearing in mind that the manufacturer's sound power rating is obtained using a uniform velocity distribution throughout the diffuser neck or grill collar. When balancing dampers are installed immediately before the diffuser, or if a duct turn precedes the entrance to the diffuser, airflow will be turbulent and the noise generated by the device will be substantially higher than the manufacturer's published data.

A misalignment or offset that exceeds approximately one-quarter diameter in a diffuser collar length of two diameters can also cause a significant change in diffuser sound power level above that of the manufacturer's published data. Figure A-41 shows an example of increased pressure drop and increased noise level for a flexible duct connection. When there is an offset of only  $1/8$  the diameter, there is no appreciable change in the diffuser performance.

Most grills and diffusers are furnished with integral volume dampers. Since dampers generate noise when partially closed, the sound power levels of the units are a result of the air volume handled by the diffuser, and the magnitude of the pressure drop across the damper.

Another interesting acoustical consideration is the noise path between adjacent rooms caused by short lengths of duct. This is called "cross talk." The most common method of controlling cross talk is to avoid connecting rooms with short lengths of duct, by lining the ducts connecting these rooms with acoustical materials, and by installing silencers (sound absorbing devices) in the duct.

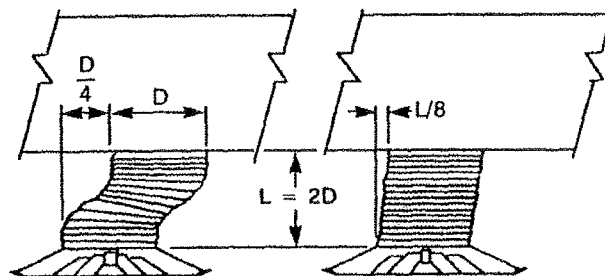

Figure A-41. Example of Increased Pressure Drop and Noise Level for Flexible Duct Connection.

Courtesy Dwyer Instruments, Inc.

Many of these acoustical considerations for VAV systems are the same for other HVAC systems. Those which are of a more critical nature for the VAV system have been discussed briefly here. Considerations for acoustical improvement on most HVAC systems are: (1) components such as fan and duct system vibration isolation, (2) more in depth study of breakout noise, duct system noise; and how to calculate each, and (3) materials and methods used to prevent acoustical problems, such as duct lagging, to prevent breakout noise. Many charts and publications from sources such as SMACNA are available for these calculations.



## 7 Acceptance Testing

Acceptance testing of a new facility's VAV system can be an important step in ensuring the system's correct and energy efficient operation. Although current construction practices should be capable of providing functional VAV systems for heating and cooling, there is no guarantee that this will happen. Corps quality assurance (QA) representative(s) have to rely, for the most part, on the competence of the contractor's quality control (CQC) to provide a proper system. Acceptance testing will assist the Corps in determining the quality of the contractor's testing, adjusting, and balancing (TAB) work. The acceptance testing procedures should be easy to use by field personnel but still provide accurate results.

Normally, after the HVAC system, including the VAV subcomponents, for a new facility has been installed by the contractor or his subcontractor, it will be tested, adjusted, and balanced by a TAB subcontractor to ensure proper operation. The TAB subcontractor documents his work in a TAB report, which includes the data collected during TAB, as well as the air flows, fluid flows, temperatures, etc. established for the system. Upon completion of TAB, the report is submitted to the Corps QA representative for review and approval.

CERL has already developed an acceptance test procedure for air supply and distribution systems. This procedure provides a relatively detailed series of acceptance tests for the HVAC system's fans, ducts, and coils, but does not cover the VAV boxes that may also be in the system. This deficiency will be corrected here.

To provide a better understanding of the TAB process, the following sections will first describe the instruments commonly used in TAB, followed by a brief description of basic TAB procedures. The final section will discuss acceptance testing of VAV systems.

## Air Measuring Instruments

Many different types of testing and measuring instruments are used in TAB work. These instruments are used for measuring pressures, temperatures, fluid flows, electrical circuits, and rotational speeds. Many of these instruments are expensive, and must be protected from dirt as well as shock and jarring. Some of the instruments can be damaged by exceeding their rated capacity. The National Environmental Balancing Bureau (NEBB) has established criteria for calibration of those instruments that require it. The most common air measuring instruments are described below.

### Manometers

*U-Tube Manometer:* This is the basic instrument for measuring air system pressures. It is a practical instrument to use, and is inherently 100 percent accurate. The U-Tube manometer consists of a U-shaped tube about half filled with liquid.

When a positive pressure is applied to one leg, as shown in the Figure A-42, it pushes the liquid down in one side and up in the other. The difference in the height (h) indicates the pressure.

When a vacuum is applied to one leg, the difference in height (h) indicates the amount of vacuum.

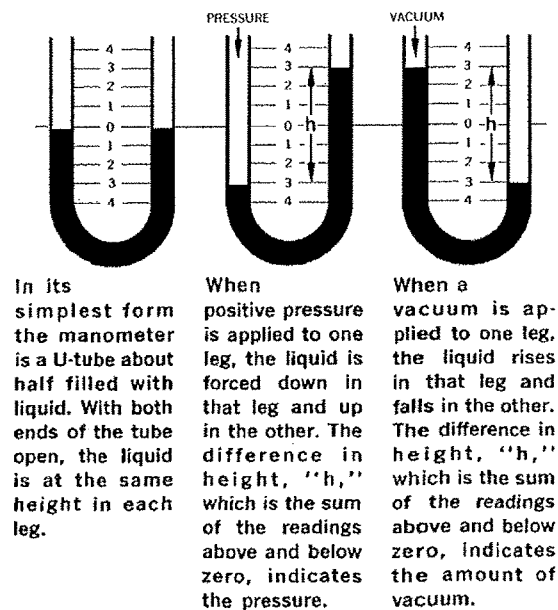
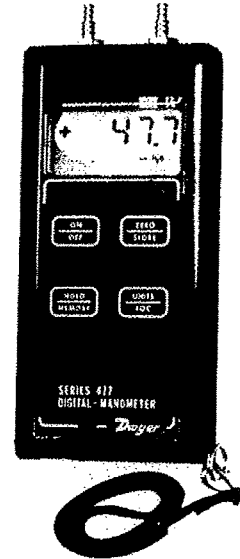

Figure A-42. Measuring Pressure and Vacuum With a Manometer.

Courtesy Dwyer Instruments, Inc.

### ***Electronic Meters***

These manometers (Figure A-43) are battery powered and contain no fluid. They are accurate, small and light, come with a digital display, and are priced competitively with liquid-filled manometers.



**Figure A-43. Electronic Meter.**  
Courtesy Dwyer Instruments, Inc.

### ***Dry-Type Pressure Gauges (Magnehelic)***

These gauges (Figure A-44) are small, light-weight, inexpensive, and relatively easy to use. They contain a diaphragm that readily moves with changes in the pressure imposed on it. Its movement is restricted by the range spring, which is calibrated to bend a definite amount when the diaphragm is subjected to a given pressure. One of the main advantages of the magnehelic gauge is that it does not contain liquid that may be spilled or can be blown out by pressure beyond the range of the instrument.



**Figure A-44. Magnehelic Gauge.**  
Courtesy Dwyer Instruments, Inc.

### ***Pitot Tube***

The primary use of the Pitot tube (Figure A-45) is to measure the velocity in ducts to determine the duct airflow (cfm). The pitot tube can be used to measure any one of the three basic pressures (total pressure, static pressure, and velocity pressure) when used with the proper hose hook-ups (Figure A-46).

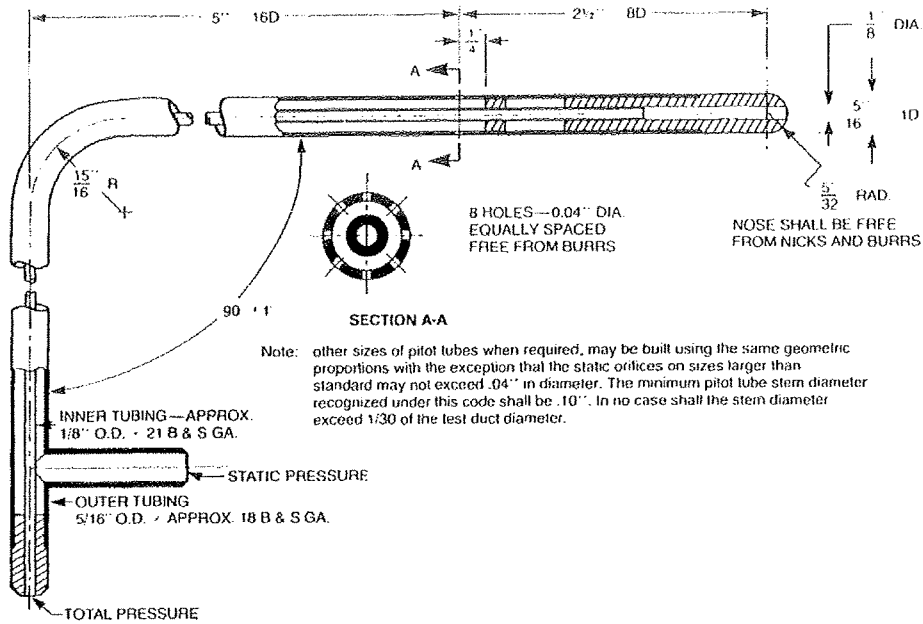

**Figure A-45. Pitot Tube.**

SMACNA, *HVAC Systems - Testing, Adjusting & Balance*, 2<sup>nd</sup> Ed., 1993. Used with permission.

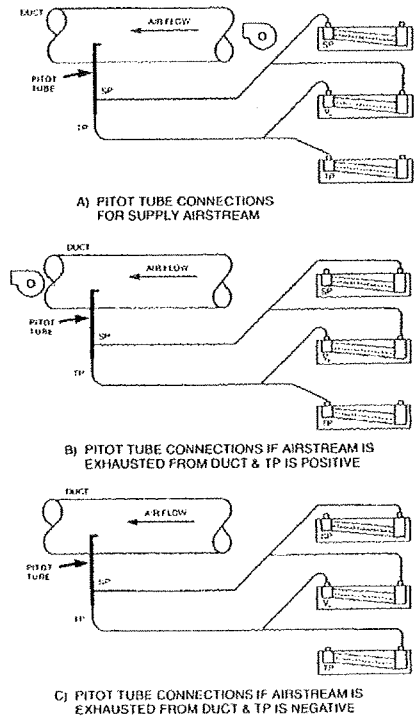

**Figure A-46. Variation of Pitot Tube Connections.**

SMACNA, *HVAC Systems - Testing, Adjusting & Balance*, 2<sup>nd</sup> Ed., 1993. Used with permission.

**Use of the Pitot Tube:** The correct procedure for measuring velocities in ducts are listed below:

Measure the size of the duct (free inside dimensions of the duct where the air is passing through), and determine the cross-sectional area (in sq ft).

To perform a pitot tube traverse of a duct, readings must be taken in the duct at equal intervals. Figure A-47 illustrates the procedure.

In round ducts, reading should be taken at the centers of equal concentric areas (Figure A-48). Preferably, 20 readings should be taken, with 10 along each of two diameters.

Use the worksheet on the next page to calculate volumetric air flow at fan outlet or zone. Divide duct to be measured into 16 blocks. Use manometer and pitot tube to take readings of velocity pressure at the centerpoint of each block. Convert the velocity pressure in each block to velocity using AABC or SMACNA conversion tables or the formula  $v = 4005\sqrt{VP}$ , where V is velocity in fpm, and VP is velocity pressure in inches of water.

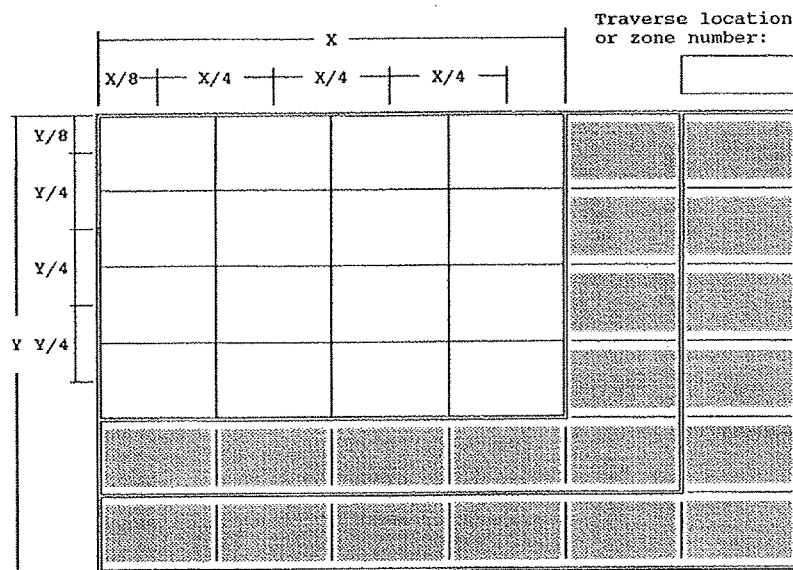

Note: If the maximum distance between traverse points is greater than 6", expand the duct traverse diagram as necessary by using the shaded blocks.

$$\text{Average Velocity (fpm)} = \frac{\text{sum of readings}}{\text{number of readings}}$$

$$\text{Net Area (sq ft)} = \frac{\text{duct width} \times \text{duct height}}{144}$$

$$\text{Volumetric Air Flow} = \text{Average Velocity} \times \text{Net Area}$$

	Average Velocity (fpm)	Net Area (sq ft)	Volumetric Air Flow (cfm)
Design			
TAB			
Actual			

Figure A-47. Duct Traverse Worksheet.

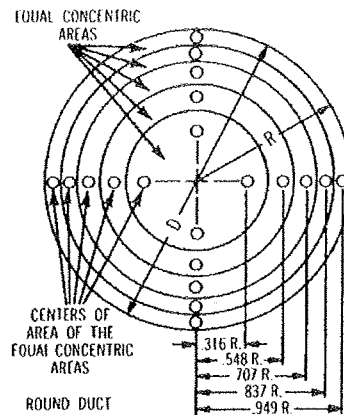

Figure A-48. Readings From Equal Concentric Areas of a Round Duct.

Courtesy Dwyer Instruments, Inc.

### ***Rotating Vane Anemometer***

The rotating vane anemometer (Figure A-49) consists of a propeller connected to a dial that is calibrated in feet. It is used for the measurement of supply, return, and exhaust air quantities at registers and grilles.

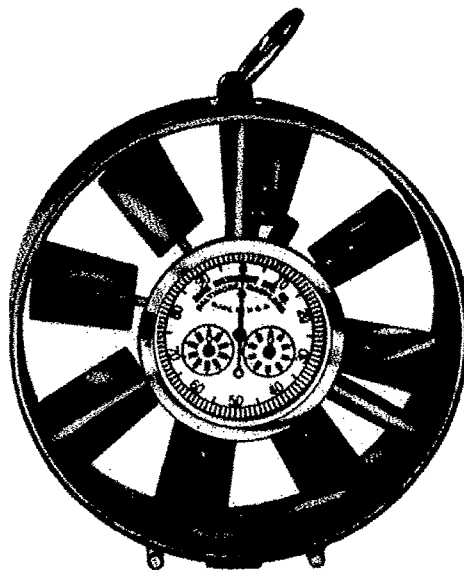
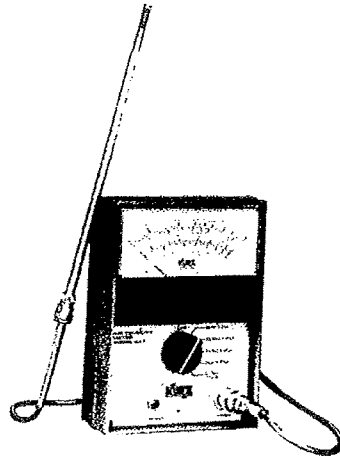

Figure A-49. Rotating Vane Anemometer.

Source: Davis Instrument Mfg. Co., Inc. Used with permission.

### ***Hot-Wire Anemometer***

This instrument (Figure A-50) is used to measure very low air velocities such as room air currents, and airflow in hoods and troffers. It can also be used for measurements at grilles and diffusers, although much less frequently than other velocity measuring instruments. It operates on the principle that the resistance in a wire will increase when heated. The probe is extremely directional and delicate and must be held at right angles to the airflow.

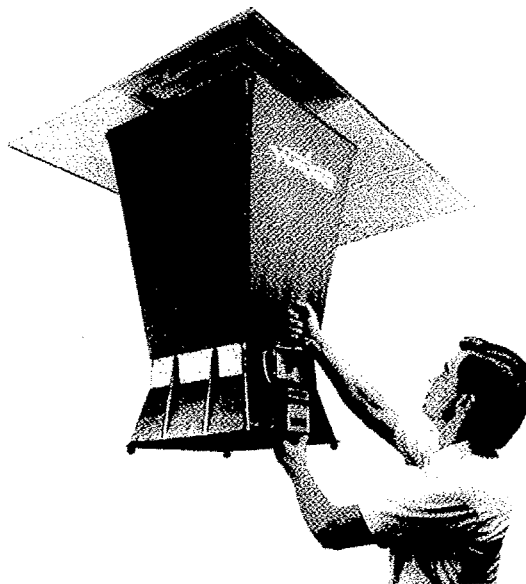

**Figure A-50. Hot-Wire Anemometer.**

Source: Davis Instrument Mfg. Co., Inc. Used with permission.

### ***Flow Measuring Hood***

The flow measuring hood (Figure A-51) is used to measure air distribution devices directly in cfm when balancing a large number of ceiling diffusers or balancing troffer diffusers. The flow hood is rapidly becoming the most popular instrument in the TAB industry for measuring airflow.



**Figure A-51. Flow Measuring Hood.**

Source: Shortridge Instruments, Inc. Used with permission.

## Testing, Adjusting, and Balancing

*Testing* uses specialized instruments to measure temperatures, pressures, rotational speeds, electrical characteristics, velocities, and air and water quantities to evaluate the equipment and system performance.

*Adjusting* is the final setting of balancing devices such as dampers and valves. Adjusting also includes setting the automatic control devices such as thermostats and pressure controllers.

*Balancing* is the regulation of air flow through the system. The wrong amount of air flow through individual diffusers can lead to complaints of drafts and/or excessive noise. It can also cause stuffiness and poor temperature control.

Preparation for TAB should not wait until after construction has started. TAB should be considered **during design** of the HVAC system (see Chapter 3, p A-61). Only a trained technician from a certified TAB firm (normally AABC or NEBB) should carry out the TAB process. Certification requirements are generally provided in the construction specifications. The following information is given to provide an understanding of the TAB process.

### ***Preliminary Steps***

These steps are standard TAB practice and are the minimum that should be performed by the TAB firm. Failure to follow these may result in a poor TAB process. Corps QA representatives should confirm that these steps are actually completed.

1. Procurement of data:
  - a. Contract drawings: Up-to-date contract drawings.
  - b. Specifications: These will spell out exactly what data and testing are required, and what guidelines or balancing procedures are desired.
  - c. Submittal data: Obtain all applicable approved equipment submittals, especially for the following equipment:
    - i. Fans: Include performance data, physical characteristics, fan curves. Pay close attention to the external and total static pressure ratings of fans.



- ii. Air terminals: Include air pressure loss at design flow conditions, sound pressure data, air pattern adjustment, and recommended testing procedure. Note whether the terminal has the means for airflow adjustment or if auxiliary dampers must be used.
  - iii. Air Distribution devices: List components and related capacities. List air distribution devices such as variable volume boxes and static pressure dampers.
  - iv. Primary heat exchange equipment: Performance data for boilers, chillers, cooling towers, and heat exchangers should be examined to ensure that unit capacity and pressure losses are within acceptable tolerances.
  - v. Terminal heat exchange equipment: Performance data for HVAC unit coils, reheat coils, fan coil units, and unit heaters should be reviewed to ensure temperature and pressure ratings comply with design requirements.
2. Review and Analysis of Systems:
- a. Review the plans, specifications, and equipment data.
  - b. Prepare a schematic layout of each duct and piping system.
  - c. Prepare the test report forms (normally AABC or NEBB).
  - d. Complete systems checklist.
  - e. Duct system checks. Observe the ductwork to see if it is complete and installed correctly. Does the installation match the plans? Is the system really ready for balancing? Verify that all terminal devices are installed and that their dampers are open. Inspect the system for leakage.

### ***Final Testing, Adjusting, and Balancing Procedures***

As the TAB subcontractors technicians go through their TAB work, they will generally follow the steps listed below. The Corps QA representative must be present during TAB to observe that all of these steps have been completed and performed correctly.

1. Assemble the previously prepared paper work, drawings, etc. for the system that you are starting on. Make sure that all preliminary procedures have

been performed. Check dampers and drives and verify that nobody is working in, on, or around the equipment to prevent injuries upon start up.

2. Using standard forms, set up AHU to design condition. Check:
  - a. rotation
  - b. rpm
  - c. belts
  - d. dampers
  - e. motor voltage
  - f. motor amps to verify no overload
3. For pressure independent systems, start air balance by cycling VAV box closest to fan through maximum and minimum air flows, filling out proper forms.
  - a. Set at full open and measure airflow.
  - b. Set at minimum open and measure airflow.

Continue until all boxes are cycled.

4. If system has no diversity, set all boxes at full cool.
  - a. Read static pressure at AHU and fill out proper forms.
  - b. Traverse supply duct to verify total airflow.
5. If system has diversity, set a required number of VAV boxes, as determined by reviewing the building heat gain/heat loss calculations, and determine the peak at maximum load time. Once the peak load boxes are selected, they are set for maximum flow, and the remaining boxes are set for minimum flow. This procedure simulates a maximum cooling situation within a building or a specific area of a building.
  - a. Read static pressure at AHU and fill out proper forms.
  - b. Traverse supply duct to verify total airflow.

6. If a system does not perform to specifications, as determined through the above balance procedures, some items which might indicate improper performance are:
  - a. Low airflow
  - b. High airflow
  - c. Too high static pressure
  - d. Too low static pressure
  - e. Excess amps to motors
  - f. Insufficient amps to motors
  - g. Air noise.

The engineer and contractor should be contacted to perform necessary modifications to bring system up to design specifications.

NOTES:

A. If VAV system has pressure dependent VAV boxes, balancing becomes more complex since box airflow somewhat depends on duct static pressure. The general procedure is followed, except additional sequential readings normally are required to ensure proper airflow.

B. Diversity is when a single VAV system serves many areas within a building that do not reach their peak cooling load at the same time, thereby reducing the maximum airflow required at a specific time.

### **Acceptance Testing for Performance Verification**

The Corps QA representative should perform the following checks or request that the TAB subcontractor perform them in the QA representative's presence. These checks will allow the representative to make a quick verification that the system has been set up and is operating as specified and designed.

1. General
  - a. Vary room thermostat to check VAV box performance

- b. Check accuracy of several room thermostats
  - c. Confirm supply air temperature in room
  - d. Check diversity of system
  - e. Confirm flow at several diffusers at minimum and maximum flow
  - f. Confirm building pressure is correct
2. Air handling unit, check:
    - a. Rotational direction of motor and fan
    - b. Belt tightness
    - c. Motor name plate data
3. After setting system to operate at a maximum condition (set thermostat), check:
    - a. Motor voltage
    - b. Motor amps
    - c. Rpm of motor and fan
    - d. External static pressure
4. Verify performance of selected VAV box:
    - a. Check VAV box inlet static pressure at several boxes. Compare with manufacturer's requirements.
    - b. Set boxes to minimum flow and confirm system response
    - c. Set selected VAV boxes to maximum flow by adjusting thermostat
      - i. Measure pressure drop across VAV box (Figure A-52)
      - ii. Determine cfm using chart on side of VAV box
    - d. Confirm proper VAV box damper operations at several locations

The data checked above should be compared against the measurements recorded by the TAB subcontractor in the TAB report. The worksheet provided at the end of this chapter may be used for this purpose. Significant discrepancies or deviations between these measurements and those in the TAB report indicate a potential problem in installation or adjustment of the system. The causes for the discrepancies or deviations must be determined, and corrected by the TAB subcontractor.

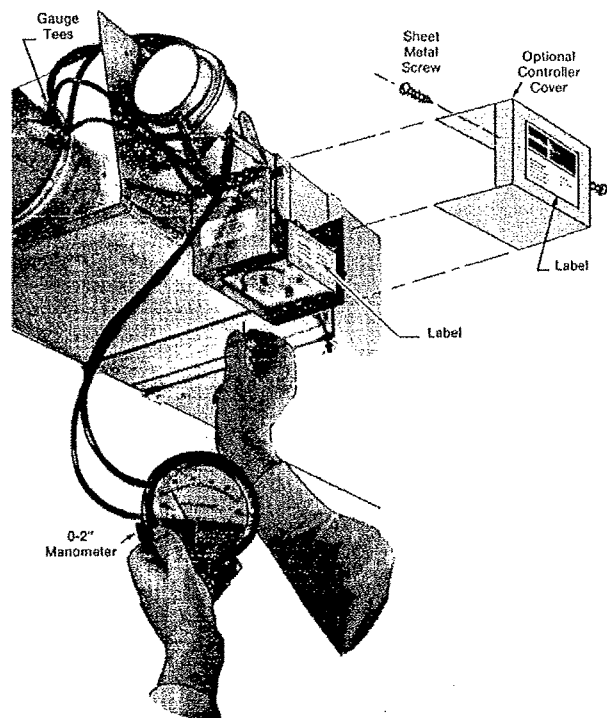

Figure A-52. Measuring Pressure Drop Across VAV Box.

Provided by Titus.

## VAV SYSTEM ACCEPTANCE TESTING CHECKLIST

PROJECT: \_\_\_\_\_

LOCATION: \_\_\_\_\_

NAME: \_\_\_\_\_

General	Correct		Date Checked
	yes	no	
1. Vary room thermostats to check VAV box performance			
2. Check accuracy of several room thermostats			
3. Confirm supply air temperature in room			
4. Check diversity of system			
5. Confirm flow at several diffusers at min. and max. flow			
6. Confirm building pressure is correct			

Air Handling Unit Checks	Correct		Date Checked
	yes	no	
1. Rotational direction of motor			
2. Rotational direction of fan			
3. Belt tightness			
4. Motor name plate data (verify)			

Air Handling Unit Measurements	Design	TAB	Actual
1. Rpm of motor			
2. Rpm of fan			
3. Motor voltage			
4. Motor amps			

Air Handling Unit External Static Pressure	Design	TAB	Actual
1. Inlet side of AHU mixing box			
2. Outlet of AHU			
3. Traverse of discharge duct			

VAV Box Measurements				
Box No.	Measurements	Design	TAB	Actual
	1. VAV box inlet static pressure			
	2. Pressure drop across VAV box			
	3. cfm			
	1. VAV box inlet static pressure			
	2. Pressure drop across VAV box			
	3. cfm			
	1. VAV box inlet static pressure			
	2. Pressure drop across VAV box			
	3. cfm			

## Appendix A Annex: Humidification

### The Need to Humidify

Control of relative humidity (RH) is essential for maintaining comfortable working conditions, proper functioning of sophisticated machinery and office equipment, and most important, the efficient use of energy.

If the temperature of air is increased without adding moisture to the air, RH is decreased. When RH is allowed to decrease significantly, either as a result of a heating system or from heat generated as a by-product of working machinery, lighting, or other energy released, a "dry air" condition is created. This dry air literally sucks the moisture out of everything—people, places, and things. For instance, dry air causes a migration of moisture from hygroscopic materials such as wood, paper, textiles, leather, or food. When these materials lose their moisture to dry air, physical changes of shrinkage, cracking, and hardening occur.

Dry air causes problems that range in severity from merely annoying, to extremely expensive, to dangerously life-threatening. In people, dry air sucks the moisture out of their respiratory systems, making them susceptible to colds, sore throats and other respiratory problems. It causes dry, flaky skin problems, and it generates static electricity in their hair (making hair unmanageable), in their clothes (making them uncomfortable), and their bodies (causing shocks). In controlled environments such as computer rooms, research laboratories, and industrial "clean rooms," static electricity can create serious problems. Static electricity can ruin computer programs that are stored on electronically sensitive tapes and disks. It also attracts dirt and dust in clean rooms where sensitive materials and products are manufactured. Hospitals must maintain high levels of humidity to control static electricity in the presence of high levels of oxygen and other potentially explosive gases.

An important consideration in military installations is the level of productivity. Dry air feels cold, even at higher temperatures. When people feel cold and uncomfortable, they are demonstrably less productive. Consequently, building temperatures (and energy costs) have to be raised in order for people to function

efficiently. But when the humidity level is correct, building temperatures can be lowered without changing the comfort level.

## Psychrometrics

Air humidification and dehumidification are defined as the addition and subtraction of moisture from the air respectively. Each of these conditions is a change of state from liquid to gas or gas to liquid. Each occurs at a constant dry-bulb temperature, but of varying wet-bulb temperature. The same process is used for adding or subtracting latent heat. It also uses the same vertical line on Figure A1-1 at a constant dry-bulb temperature.

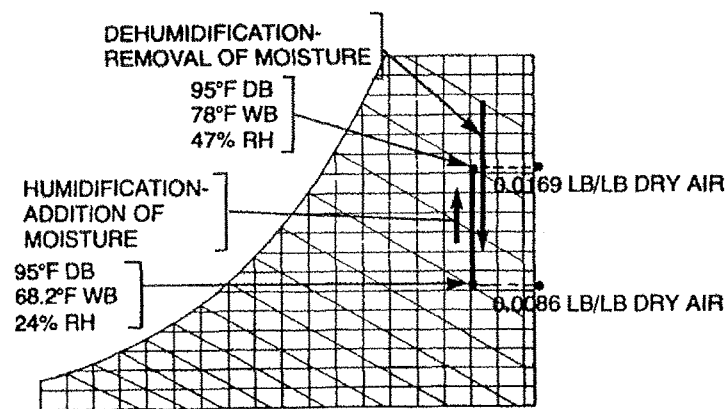

Figure A1-1. Humidification and Dehumidification.

*Environmental Systems Technology*, W. D. Bevirt, 1984. Reprinted with permission of the National Environmental Balancing Bureau.

Humidification and dehumidification are both latent heat processes, and both are shown on the same chart.

In the following example, the only constant value is the dry-bulb temperature; all other properties increase for humidification and decrease for dehumidification. This process is an illustration and normally cannot be reproduced in environmental systems.

Example 1:

Find the amount of moisture required to increase the humidity of 1 lb of air at 95 °F and 24 percent RH to 95 °F and 47 percent RH.



Solution:

Plot the points on a psychrometric chart (Figure A1-1) and read the values on the right hand side:

95°F DB, 47% RH = 0.0169 lb/lb dry air or (118 gr/lb)

95°F DB, 24% RH = 0.0086 lb/lb dry air or (60 gr/lb)

Added moisture = 0.0083 lb/lb dry air or (58 gr/lb)

## Absorption

Absorption of steam into the air is very important. Some steam humidifier dispersion tube designs fail to mix the steam with the air adequately. Poor mixing of air and steam will result in slow absorption of steam into the air. This means trouble because unabsorbed steam collects on fans, dampers, turning vanes, and other obstructions in the duct. The results can be wet, leaking ducts, wet floors and equipment, and even algae and bacteria growth that could eventually be dispersed into the space being conditioned.

Steam goes through two changes of state as it becomes absorbed. When using steam injection or dispersion tubes in a duct, the absorption process is as follows. As the steam emerges from the dispersion tubes' discharge holes, it is invisible. The first change of state occurs as the steam almost instantly changes into a white fog of tiny water droplets. As the fog moves downstream and expands, it goes through the second change of state as it disappears. The second change of state should occur as quickly as possible, before anything in the duct gets wet.

The steam is turned into fog because the comparatively cool air that receives the steam becomes "supersaturated," causing excess moisture to condense and form a visible white fog. As it condenses, 970 Btu's of heat per pound of steam is released into the mixture of steam and air. As the visible fog moves downstream and fans out, it gradually re-absorbs this heat and re-evaporates, changing back into invisible vapor.

### ***Fog Control***

The air travel distance required for the two changes of state to occur is called the absorption distance or "fog travel distance." When using the dispersion tube method for injecting steam into the system, it is important to consider the distance at which these state changes take place. The conventional dispersion tube puts off steam, which requires a longer distance than a steam-to-steam dispersion tube. The conventional tube has a row of holes punched in the top of the tube. Condensate usually forms at these holes and flows down both inside and outside the tube. The outside condensate drips to the floor of the duct, and causes wetness problems.

In the steam-to-steam tube design, nylon inserts reach almost to the center of the dispersion tube so only the hottest, "driest" steam is discharged into the air stream. Any condensate on the inner walls of the tube collects on the tube bottom and drains back to the humidifier.

Figure A1-2 illustrates the air travel distance for conventional dispersion tubes vs. steam to steam dispersion tubes. Figure A1-3 shows sections of the steam-to-steam and conventional dispersion tubes, respectively.

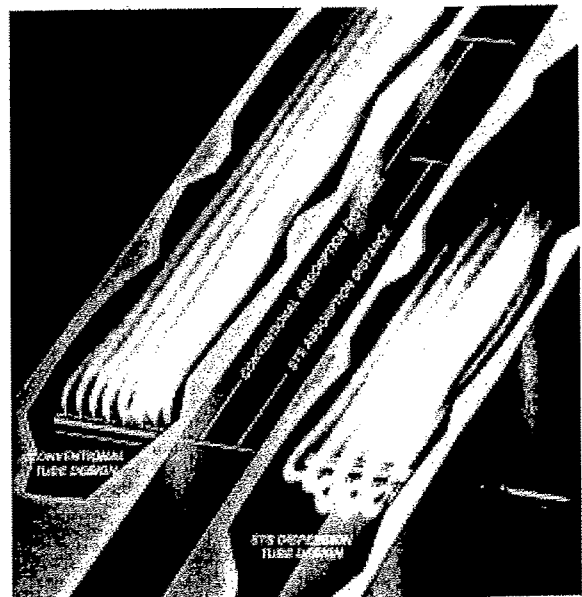

**Figure A1-2. Air Travel Distance Comparison.**

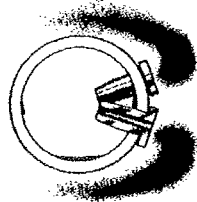
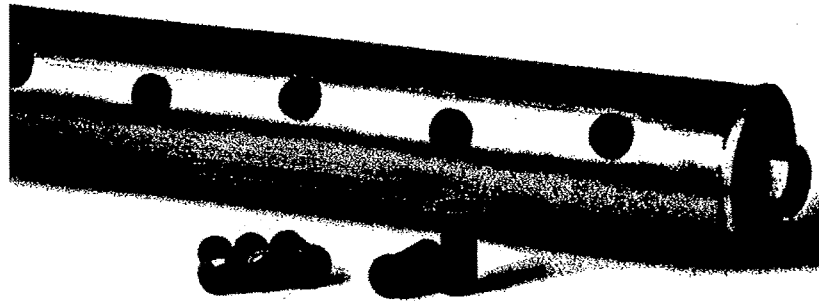

In the STS tube design, nylon inserts reach almost to the center of the dispersion tube, so only the hottest, 'driest' steam is discharged into the air stream. Any condensate on the inner walls of the tube is simply collected on the tube bottom and drains back to the humidifier.

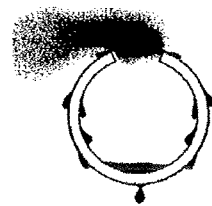

A conventional dispersion tube has a row of holes punched in the top of the tube. Condensate usually forms at these holes and flows down both inside and outside the tube. Outside condensate drips to the floor of duct and causes wetness problems.

Figure A1-3. Sections of STS and Conventional Dispersion Tubes.

## Humidifier Types

### *Area Humidifier (for wide open spaces)*

This type of humidifier is used in spaces such as warehouses and shops. They operate as follows:

1. Steam enters separator from steam supply.
2. Condensate is removed and flows to steam trap in lower section of separator.
3. Dry steam rises through deflector plate into upper portion of separator surrounding inner re-evaporation chamber with steam at line pressure.
4. When humidifier valve opens, steam flows through piping into valve, through inner chamber, and through wood silencer into humidified space (any condensate passing through valve and piping is re-evaporated by line pressure steam jacketed inner chambers).
5. Electric fan disperses steam in room.

As fog is carried away from the humidifier by the fan air stream, it tends to rise toward the ceiling. If this fog contacts any solid surface (columns, beams, ceilings, pipes, etc.) before it disappears, it will probably collect and drip as water.

Figure A1-4 shows the various components of the area type humidifier.

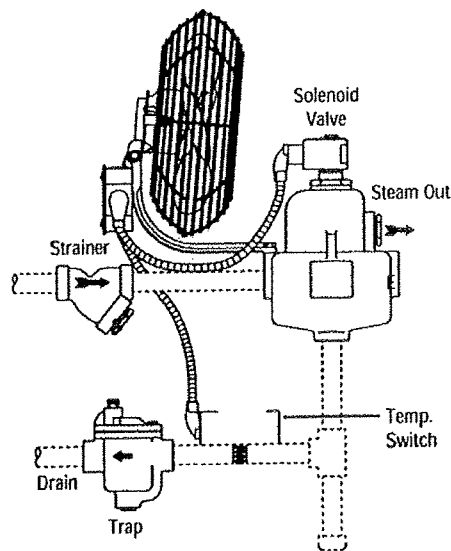

**Figure A1-4. Components of an Area Humidifier.**

Source: *Armstrong Humidification Handbook*, 1995. Used with permission.

### ***Duct Type Steam Humidifiers***

As mentioned before, area type humidifiers are used mainly in wide open areas. This application is not wise in places such as hospitals and small spaces with low ceilings. For these spaces, especially where VAV systems are used, duct type humidifiers are best. Generally, two types of injection humidifiers are used: single dispersion tube and multiple dispersion tube. These steam injection humidifiers are available to fit any size application. In most applications, the single dispersion tube humidifier is sufficient. It is commonly used when requirements for final duct relative humidity is below 60 percent or when there are 10 to 20 ft of straight duct downstream with no internal obstructions.

When conditions call for extremely short absorption distances, it is best to use a multiple dispersion tube unit. Two types of multiple dispersion tube units are

available for application. These are the Mini-Bank and Maxi-Bank humidifiers.\* For ducts of small cross-section, the Mini-Bank is used. The Maxi-Bank is for larger ducts and may be assembled on site.

**Single dispersion tube humidifiers.** In Figure A1-5, supply steam (1) circulates through the stainless steel jacket of the dispersion manifold (2) where its heat prevents condensation of steam being dispersed. From the manifold, supply steam flows into the separator chamber (3) through the directing nozzle (4) onto the conical separating baffle (5). Condensate is separated and flows to the bottom of the separator, and is discharged through the steam trap (6). Dry steam flows upward in the separator chamber, and is regulated by the control valve (7). Upon leaving the control valve, the steam passes through a final separator (8), which removes any condensate that may form, particularly on start up, and directs it back into the re-evaporation chamber (9) within the primary separator. Dry steam is then dispersed into the duct through the orifices of the steam jacketed stainless steel dispersing tube (10). A fine screen (11) covers the orifice to minimize noise. Figure A1-6 illustrates various mountings for single manifold humidifiers.

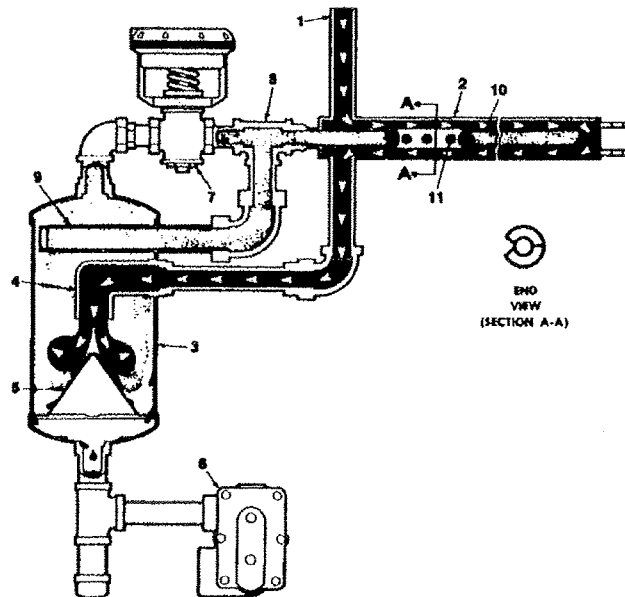
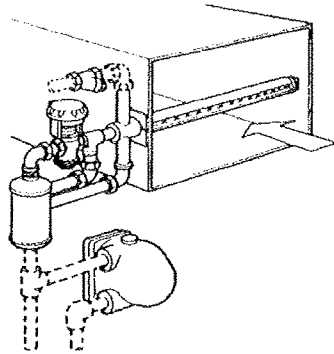
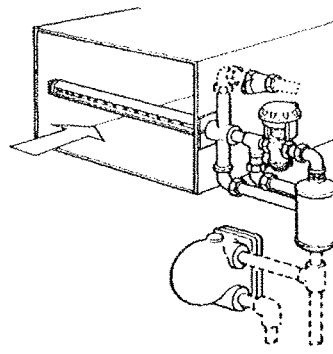

Figure A1-5. Single Dispersion Tube Humidifier.

\* A commercial product of the "DRI-STEEM" Humidifier Company, Hopkins, MN.



Typical Horizontal Installation  
LEFT HAND  
MOUNTED



Typical Horizontal Installation  
RIGHT HAND  
MOUNTED

Optional Humidifier Hookups

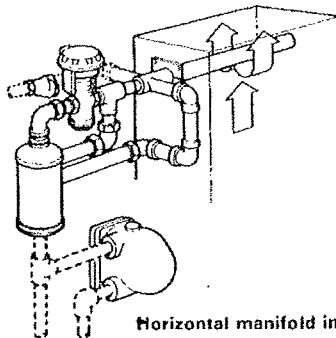

Horizontal manifold in vertical duct

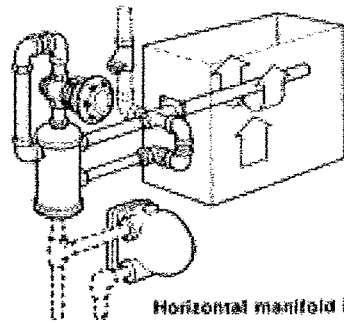

Horizontal manifold in vertical duct

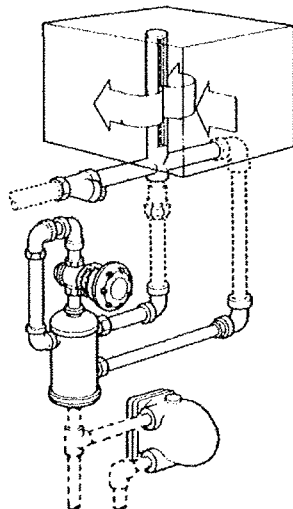

Vertical manifold installation

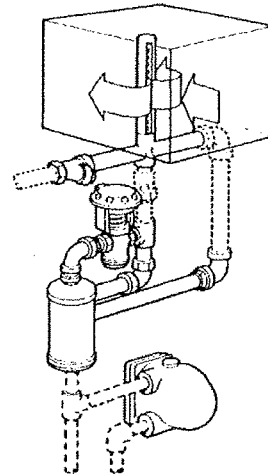

Vertical manifold installation

Figure A1-6. Various Mountings for Single Manifold Humidifiers.

**Multiple dispersion tube humidifiers.** A Mini-Bank multiple-tube humidifier is for small ducts up to 24 in. high and 48 in. wide. Because they are small, they are pre-assembled and ready for hook up.

The Maxi-Bank multiple-tube humidifiers are used when nearby downstream devices such as fans, coils, sound traps, and dampers could collect moisture and cause wetness problems in the air handling system. Formulas and tables for figuring the absorption distances with given temperatures and cfm are generally given with example problems for each model in the manufacturer's catalogs.

## Trouble Shooting

### ***Too Much Humidity***

1. Humidity controller out of calibration.
2. Valve stem sticking.
3. Valve spring broken.
4. Foreign matter preventing valve from closing.

### ***Too Little Humidity***

1. Strainer screen plugged.
2. Stop valve not fully open.
3. Silencer media (steel wool) dirty.
4. Humidity controller out of calibration.
5. Inadequate steam pressure.
6. Undersized humidifier.
7. Automatic control valve not opening fully.
  - a. Pneumatic valve operator leaking air.
  - b. Valve stem sticking.

### ***Humidifier Discharges Water***

1. Faulty drainage:
  - a. Return line pressure greater than humidifier pressure.
  - b. Return line flooded.
  - c. Dirty steam trap.
  - d. Too much vertical lift.
  - e. Wrong type steam trap; float type must be used.
2. Faulty steam supply:
  - a. Humidifier supply not taken from top of main.

- b. Too low (below 2 psi steam pressure).
- c. Long, untrapped supply line.
- d. Steam main flooded due to priming boiler.

***Humidity Swings Above and Below Control Point***

1. Boiler pressure swings too widely.
2. Faulty or inaccurate humidity controller.
3. Humidifier oversized.
4. Humidity controller in poor sensing location.
5. Pressure reducing valve not controlling accurately.



## Glossary

**AIR TERMINAL:** See VAV BOX.

**AIR VALVE ACTUATOR:** A device which converts the control system signal into a useful function such as opening and closing the air valve.

**ASPECT RATIO (DUCT):** The ratio of length to width of an opening or core of a grille.

**BEADING:** The triangular or semi-circular crease in a duct (with spacing as indicated on page 3-24) that runs along the depth of the duct (not the length).

**BLOCK TIGHT:** Zero airflow into and out of the block.

**BREAKOUT NOISE:** Sometimes referred to as "flanking" or duct radiation. The transmission or radiation of noise from some part of the duct system to an occupied space in the building.

**CLEAN ROOMS:** A room designed to be as close to 100 percent free of contaminants as possible—hospital rooms, research laboratories, etc.

**COMPRESSED AIR JET PRINCIPLE:** As compressed air is forced through a nozzle or chamber of some kind, the air expands and provides a driving force.

**CONDENSATE:** The liquid formed by condensation of a vapor: in steam heating, water condensed from steam; in air conditioning, water extracted from air as by condensation on the cooling coil of a refrigeration machine.

**CROSS BREAKING:** Two creases (along the surface of the duct) that cross each other at the center of a rectangle, whose diagonals are the creases.

**DAMPER:** A device used to vary the volume of air passing through an air outlet, inlet, or duct.

**DEADBAND:** In HVAC, a temperature range in which neither heating nor cooling is turned on. In load management, a kilowatt range in which loads are neither shed nor restored.

**DUCT AIR VELOCITY:** High (2,500 fpm and up), Medium (1,100-2,500 fpm), Low (1,100 fpm and below).

**DUCT LAGGING:** A 1- to 2-in. thickness of glass fiber or rock wool covered with an air-impervious layer of material having a mass of at least 1 lb per sq ft. Its purpose is to dampen the duct surfaces and prevent contact between the duct surfaces and the mass layer.

**DUCT RUNOUTS:** The end of the ductwork, as in diffuser locations where air leaves the duct.

**DUMPING DIFFUSERS:** Dumping occurs when the volume of air leaving the diffuser is far less than the diffuser was designed for with respect to its location in a space. As a result, the cold air falls almost straight down, dumping its air just below the diffuser, and not accomplishing a mix with room air.

**EXTENDED PLENUM:** This is a trunk duct of constant size (usually at the discharge of a fan, fan coil unit, mixing box, constant volume box, etc.) extended as a plenum to serve multiple and/or branch ducts (see Semi-Extended Plenum).

**EXTRACTOR:** A device located at the tee of two ducts that is used to direct air-flow. It is used mainly to divert air to branch takeoffs.

**FAN BRAKE HORSEPOWER:** The actual horsepower required to drive the fan. Included friction losses are due to air turbulence, inefficiencies in the fan, and bearing losses.

**FAN DISCHARGE PRESSURE:** The pressure read on a metering device when held right at the discharge face of the fan.

**FRICTION LOSSES:** Frictional losses are due to fluid viscosity, and are a result of momentum exchange between molecules in laminar flow and particles moving at different velocities in turbulent flow. Frictional losses occur along the entire duct length.

**HEURISTIC CONTROL:** A computerized control that proceeds along empirical lines, utilizing equations within the computer program.

**HUMIDIFIER:** A device to add moisture to air.

**HUMIDIFYING EFFECT:** The latent heat of vaporization of water at the average evaporating temperature times the weight of water evaporated per unit of time.

**HUMIDISTAT:** A regulatory device, actuated by changes in humidity, used for the automatic control of relative humidity.

**HUMIDITY:** Water vapor within a given space.

**HUMIDITY, ABSOLUTE:** The weight of water vapor per unit volume.

**HUMIDITY, PERCENTAGE:** The ratio of the specific humidity of humid air to that of saturated air at the same temperature and pressure, usually expressed as a percentage (degree of saturation; saturation ratio).

**HUMIDITY RATIO:** The ratio of the mass of the water vapor to the mass of dry air contained in the sample.

**HUMIDITY, RELATIVE:** The ratio of the mol fraction of water vapor present in the air to the mol fraction of water vapor present in saturated air at the same temperature and barometric pressure. It approximately equals the ratio of the partial pressure or density of the water vapor in the air to the saturation pressure or density, respectively, of water vapor at the same temperature.

**HUMIDITY SENSING ELEMENTS, ELECTRICAL:** These cause a change in characteristics (resistance or capacitance) due to the hygroscopic nature of the elements used.

**HUMIDITY SENSING ELEMENTS, HYGROSCOPIC:** Change in size or form to cause a mechanical deflection. Some of the organic materials used are hair, wood, paper, or animal membrane, and man-made products such as nylon.

**HUMIDITY, SPECIFIC:** Weight of water vapor (steam) associated with 1 lb weight of dry air; also called humidity ratio.

**INFILTRATION:** The natural exchange of outside air directly into the building.

**INTERFACING:** A point or means of interacting between two systems.

**INTERNAL HEAT GAIN:** Heat generated from within the space being considered from sources such as people, lights, motors, etc.

**JOURNAL BEARINGS:** Bearings that support the shaft of a pump in the inlet or adjacent to it.

**LATENT HEAT:** The amount of heat necessary to change the quantity of water to water vapor without changing either temperature or pressure. Latent heat is removed when water vapor is condensed.

**LEAVING AIR TEMPERATURE:** Temperature of air after it leaves the cooling coil.

**LOAD CONDITIONS:** The actual physical state of the air within the space being controlled.

**LOW PRESSURE (Air System):** A forced air system that produces static pressures from zero to 2 in. of water column of pressure in a duct system.

**MAGNEHELIC GAUGE:** A pressure gauge used for air system work, and available in many different pressure ranges.

**MASTIC:** An aromatic resinous exudate from mastic trees; any of various pasty materials used as protective coatings or cement.

**MICROCOMPUTER:** A very small computer containing a microprocessor along with supporting devices such as a memory system.

**MIXING BOX (Dual Duct):** An inlet valve is positioned by a motor in response to a room thermostat to supply air at the proper temperature that satisfies the load within the space. This box is provided with warm air and cool air which are mixed in this box, and leave at a single temperature.

**PEAK INSTANTANEOUS DEMAND:** The greatest demand for a load at a given instant of time.

**PILOT RELAY:** A relay used for switching loads such as another relay or solenoid valve coils. The pilot relay contacts are located in a second control circuit. Rated in volt-amperes (VA).

**PLENUM:** An air compartment connected to one or more distributing ducts.

**PRESSURE DEPENDENT SYSTEM:** When no controls that compensate for changes in duct static pressure are utilized by the system, the air volume delivered is dependent on upstream static pressure changes.

**PRESSURE INDEPENDENT SYSTEM:** This system will deliver the required amount of air to satisfy the space load regardless of the changes in system static pressure.

**SEMI-EXTENDED PLENUM:** The semi-extended plenum is a trunk design system utilizing the concept of the extended plenum to incorporate a minimum amount of size reductions due to decreasing volume.

**SENSIBLE HEAT:** Heat that changes the temperature of the air without a change in moisture content.

**SOLAR LOAD:** The sun's rays contact the outer surfaces of a building (including window glass) generating heat on surfaces. This heat is transmitted through the walls and glazing at rates proportional to the insulating factors of each material. The transmitted heat becomes the solar load in the controlled space.

**SPACE PEAK DEMAND:** The greatest amount of kilowatts needed for a space during a demand interval.

**SUPER HEATING:** The difference between the temperature of a pure condensable fluid above saturation, and the temperature at the dry saturated state at the same pressure.

**SURGE:** The varying of airflow and static pressure due to an unstable condition in the duct system.

**SYSTEM DIVERSITY:** The ability of a single HVAC system to handle different (diverse) loads throughout a building that are all present at the same time.

**THERMOMETER:** An instrument for measuring temperature.

**THERMOSTAT:** An automatic control device actuated by temperature, and designed to be actuated by temperature.

**THERMOSTAT, DIRECT ACTING:** An instrument for activating a control circuit on sensing predetermined low temperature.

**THERMOSTAT, REVERSE ACTING:** An instrument for activating a control circuit on sensing predetermined high temperature.

**THERMOSTATICALLY CONTROLLED:** The use of a thermostat to send a signal to an operator which, in turn, will control a device or mechanism.

**THROTTLED BACK:** To reduce the flow of the medium being controlled by the mechanism (throttle).

**TRUNK DUCT:** The main duct from which branch ducts extend.

**VARIABLE SPEED DRIVE:** A device that varies the speed of a motor to match the load being put on the motor.

**VAV BOX:** Sometimes referred to as a VAV terminal. This box has controlled dampers inside that vary the volume of air sent to the controlled space.

**VENTILATION:** Bringing in outside air by use of a mechanical system.

**ZONE:** The specific section of a building controlled by a single thermostat. Buildings may be divided into many zones.

## Abbreviations

<b>AABC:</b>	Associated Air Balance Council
<b>AHU:</b>	air handling unit
<b>ASHRAE:</b>	American Society of Heating, Refrigerating, and Air Conditioning Engineers
<b>cfm:</b>	cubic feet per minute
<b>DDC:</b>	direct digital control
<b>DX:</b>	direct expansion
<b>fpm:</b>	feet per minute
<b>LAT:</b>	leaving air temperature
<b>MBtu:</b>	mega British thermal units
<b>MVR:</b>	mechanical volume regulator
<b>N.C. or NC:</b>	normally closed
<b>NEBB:</b>	National Environmental Balancing Bureau
<b>N.O. or NO:</b>	normally open
<b>OBP:</b>	bypass operator
<b>OMC:</b>	modulating control operator
<b>PDT:</b>	pressure dependent terminal
<b>PIT:</b>	pressure independent terminal
<b>RA:</b>	return air
<b>rpm:</b>	rotations per minute
<b>SA:</b>	supply air
<b>SMACNA:</b>	Sheet Metal and Air Conditioning Contractors National Association
<b>TAB:</b>	testing, adjusting, and balancing
<b>UPC:</b>	Uniform Plumbing Code
<b>VAV:</b>	variable air volume
<b>w.g.:</b>	water gauge

## Bibliography

Air Movement and Control Association, Inc. (AMCA), Publication 201-90 Fans and Systems, AMCA, Arlington Heights, IL, 1990.

American Society of Heating, Refrigerating, and Air Conditioning Engineers (ASHRAE), "Automatic Temperature Controls for Energy/Cost Effectiveness," ASHRAE Energy Professional Development Series, ASHRAE, Atlanta, GA.

ASHRAE, *Applications Handbook*, 1995.

ASHRAE, *Fundamentals Handbook*, 1997.

ASHRAE, *Systems and Equipment Handbook*, 1996.

Armstrong International, Inc., *The Armstrong Humidification Handbook*, Three Rivers, MI, 1995.

Carnes Company, Inc., Catalog, Verona, WI.

"DRI STEEM" Humidifier Company, *Humidifier Handbook*, Hopkins, MN.

Eppelheimer, Donald, "Coil Circuiting: A Key to Problem-Free DX/VAV Systems," *Contracting Business*, March 1988.

Guralnik, David B., editor in chief, *Webster's New World Dictionary, 2nd edition*, Prentice Hall Press, New York, 1986.

Honeywell, Inc., "Direct Digital Control System," Catalog of Controls for Heating, Ventilating, and Air Conditioning Systems, Wichita, KS.

National Air Filtration Association (NAFA), *NAFA Guide to Air Filtration*, NAFA, Washington, DC, 1993.



- Sheet Metal and Air Conditioning Contractors Association, "Working with Adjustable Speed Drives," Division 16/Electrical, Motor Control, National Electrical Contractors Association (NECA).
- National Environmental Balancing Bureau, *Environmental Systems Technology*, National Environmental Balancing Bureau (NEBB), Vienna, VA, 1984.
- NEBB, *Testing, Adjusting, Balancing Manual for Technicians*, April 1986.
- Omnizone, "Modulating Zone Control Systems for VAV Applications of Air Conditioning Units," Huntington Beach, CA, May 1988.
- PACE, "Central Station," Brod & McLung, Portland, Oregon.
- Sheet Metal and Air Conditioning Contractors National Association, Inc. (SMACNA), *HVAC Duct Construction Standards--Metal & Flexible, 2nd Ed.* (SMACNA, Vienna, VA, 1995).
- SMACNA, *HVAC Systems--Duct Design, 3rd Ed.*, 1990.
- Spirax Sarco, "Steam Humidifiers," Bulletin 970, Allentown, PA, April 1985.
- TempMaster - Air Distribution Products, "WATTMASTER" WCCII, Energy Management Service.
- Titus Installation Manual, "Series ESV-3000 VAV Terminal," Division of Philips Industries, Inc., Richardson, TX.
- Titus Products Catalog, "Diffusers and Terminal Units."
- Trane Air Conditioning, *Varitrane Variable Air Volume Systems Manual*, The Trane Company, La Crosse, WI, 1978.